

GoldStar



OSCILLOSCOPE OS-9000SRS
OPERATION MANUAL



GoldStar Precision Co., Ltd.

Introduction

Thank you for purchasing a Goldstar product. Electronic measuring instruments produced by GoldStar precision are high technology products made under strict quality control. We guarantee their exceptional precision and utmost reliability. For proper use of the product please read this user manual carefully.



Instructions

1. To maintain the precision and reliability of the product use it in the standard setting (temperature 10°-35° centigrade, humidity 45%-85%).
 2. After turning on-power, please allow a 15-minute pre-heating period before use.
 3. Triple-line power cord is to be used for the product. But when you are using the double-line cord, make sure to connect the earth terminal of the product to the earth at the power source for safety.
 4. For quality improvement the exterior design and specifications of the product can be changed without prior notice.
 5. If you have further questions concerning use, please contact the GoldStar Precision service center or sales outlet.
-

Warranty

Warranty service covers a period of one year from the date of original purchase.

In case of technical failure within a year, repair service will be provided by our service center or sales outlet free of charge.

We charge for repairs after the one-year warranty period expires.

When the failure is a result of user's neglect, natural disaster or accident, we charge for repairs regardless of the warranty period.

For more professional repair service, be sure to contact our service center or sales outlet.

CONTENTS

1. INTRODUCTION
 - 1-1. SPECIFICATIONS
 - 1-2. PRECAUTIONS
 2. OPERATING INSTRUCTIONS
 - 2-1. FUNCTION OF CONTROLS
 - 2-1-1. Display and Power Blocks
 - 2-1-2. Vertical Amplifier Block
 - 2-1-3. Sweep and Trigger Blocks
 - 2-1-4. Read out Function Block
 - 2-1-5. Miscellaneous Features
 - 2-2. BASIC OPERATING PROCEDURES
 - 2-2-1. Preliminary Control Settings and Adjustments
 - 2-2-2. Signal connections
 - 2-2-3. Single-trace Operation
 - 2-2-4. Dual-trace Operation
 - 2-2-5. Trigger Options
 - 2-2-6. Additive and Differential Operation
 - 2-2-7. X-Y Operation
 - 2-2-8. Delayed-time base Operation
 - 2-2-9. Read-out Operation
 - 2-3. MEASUREMENT APPLICATIONS
 - 2-3-1. Amplitude Measurements
 - 2-3-2. Time Interval Measurements
 - 2-3-3. Frequency Measurement
 - 2-3-4. Phase Difference Measurements
 - 2-3-5. Rise time Measurement
-

3. USER MAINTENANCE GUIDE

3-1. CLEANING

3-2. CALIBRATION INTERVAL

4. DIAGRAMS

4-1. EXTERNAL VIEWS

4-2. SCHEMATIC DIAGRAMS

4-2-1. Block Diagram

4-2-2. Wiring Diagram

4-2-3. Circuit Diagrams

1. INTRODUCTION

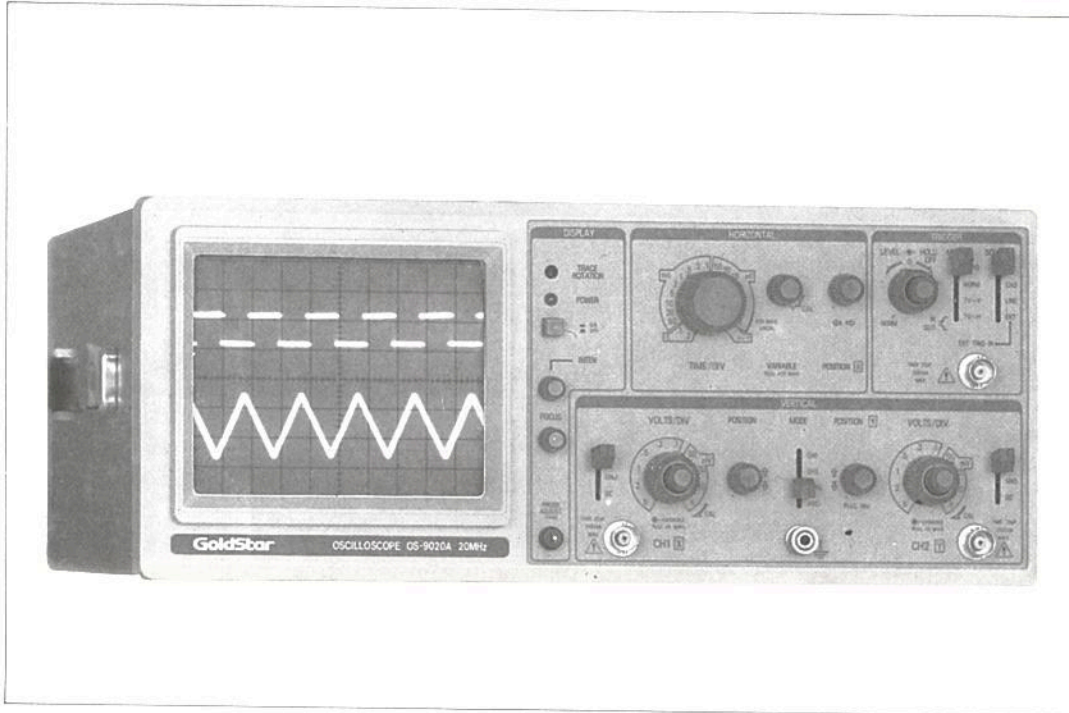

Fig.1-1. MODEL OS-9020A

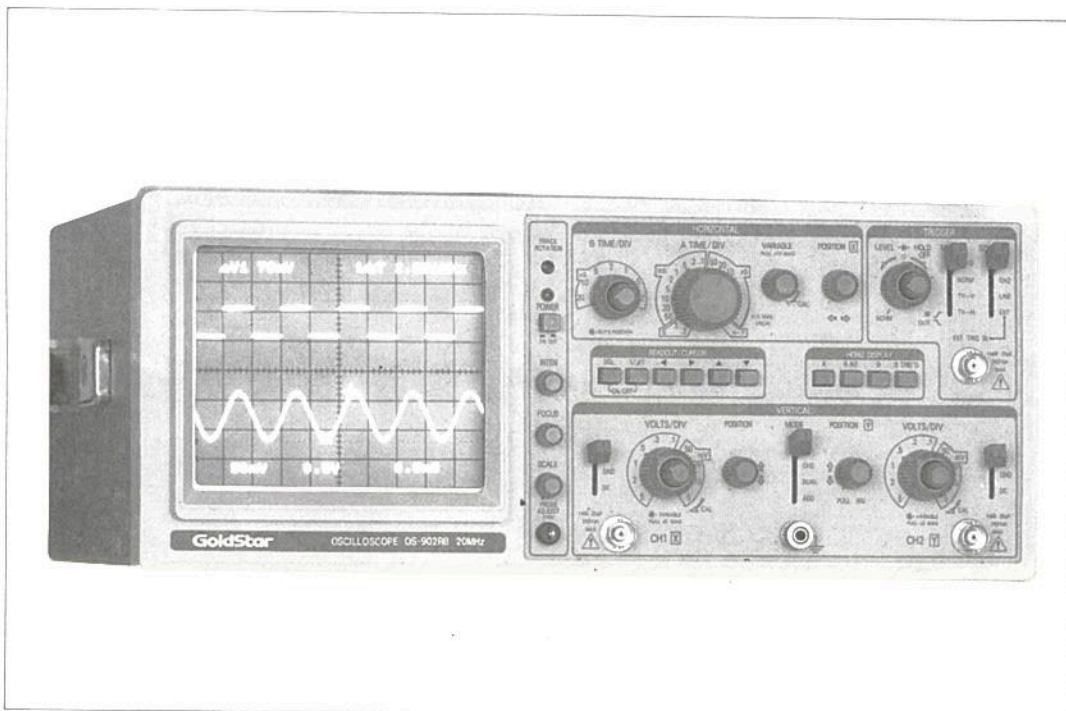

Fig.1-2. MODEL OS-902RB

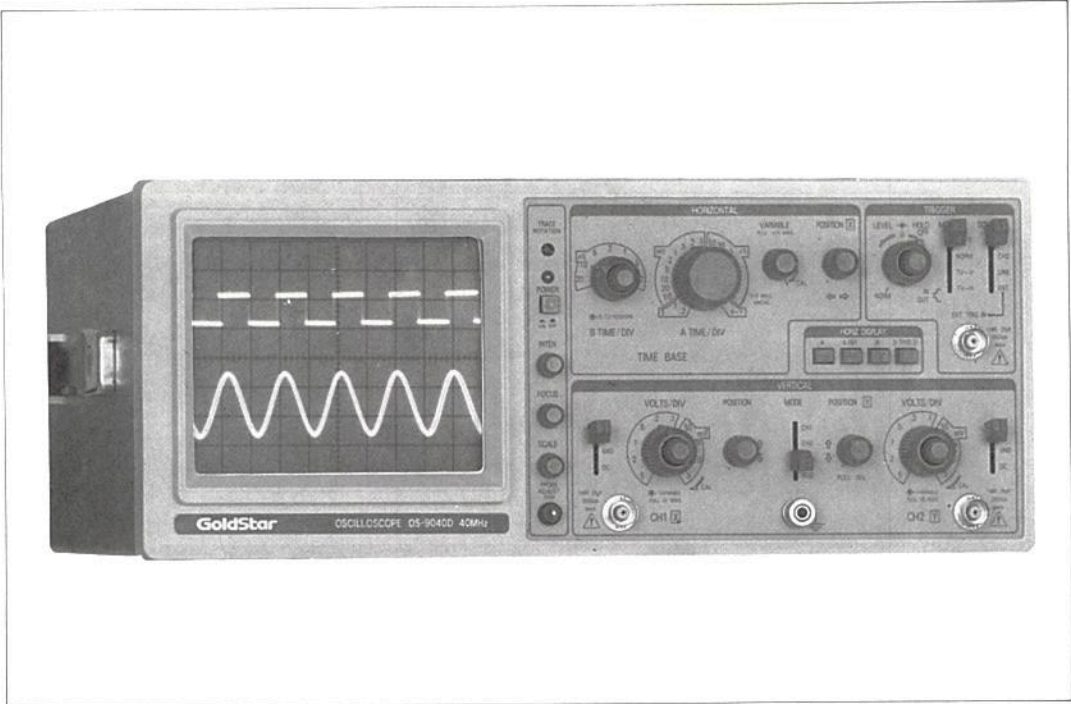

Fig.1-3. MODEL OS-9040D

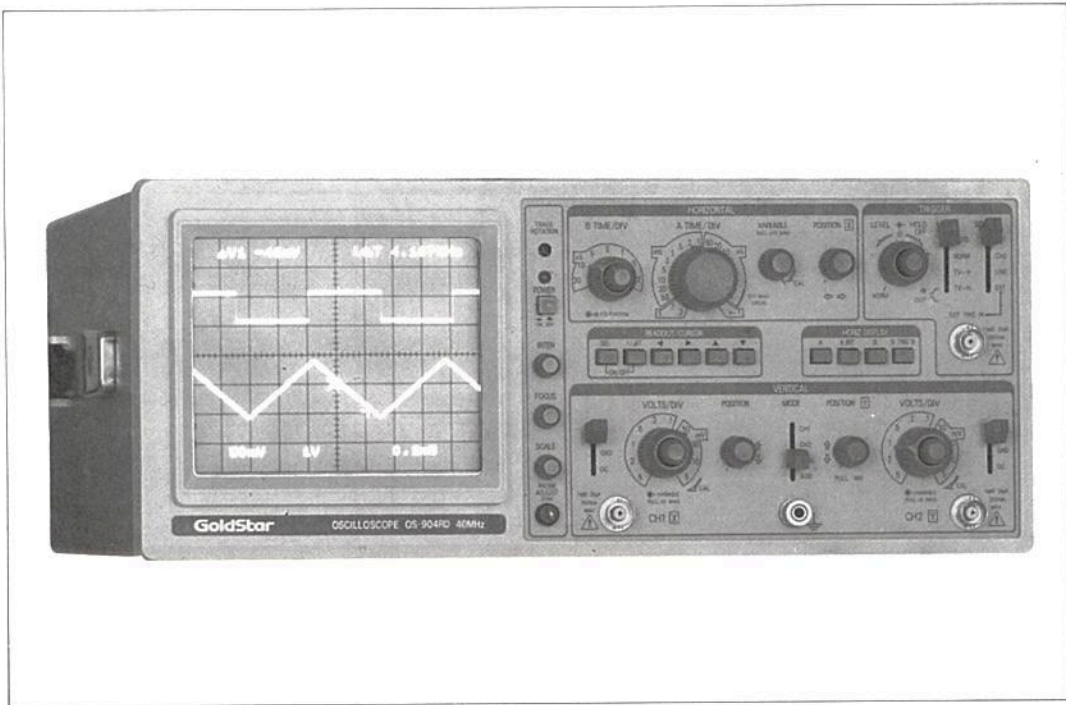

Fig.1-4. MODEL OS-904RD

1-1. SPECIFICATIONS

SPEC.	MODEL	OS-9020A	OS-902RB	OS-9040D	OS-904RD
*CRT					
1) Configuration	6-inch rectangular screen with internal graticule; 8x10 Div (1div=1Cm), marking for measurement of rise time. 2mm subdivisions along the central axis.				
2) Accelerating potential	+1.9KV approx.(ref.cathode)		+11.5KV approx.(ref.cathode)		
3) Phosphor	P31(standard)				
4) Focussing	possible	possible(with autofocus correction circuit)	possible	possible(with autofocus correction circuit)	
5) Trace rotation	provided				
6) Scale illumination	none	variable			
7) Intensity control	provided				
*Z-Axis input (Intensity Modulation)					
1) Input signal	Positive going signal decreases intensity +5Vp-p or more signal cases noticeable modulation at normal intensity settings.				
2) Band-width	DC - 2MHz (-3dB)				
3) Coupling	DC				
4) Input impedance	20K - 30K ohms				
5) Maximum input voltage	30V(DC+peak AC)				
*Vertical Deflection(1)					
1) Band-width(-3dB)	DC to 20MHz normal DC to 7MHz magnified		DC to 40MHz normal DC to 7MHz magnified		
AC coupled	10Hz to 20MHz normal 10Hz to 7MHz magnified		10Hz to 40MHz normal 10Hz to 7MHz magnified		
2) Modes	CH1, CH2, ADD, DUAL (CHOP : Time/div switch 0.2s~5mS, ALT : Time/div switch 2mS ~ 0.2uS)				
3) Deflection Factor	5mV/div to 5V/div in 10 calibrated steps of a 1-2-5 sequence. Continuously variable between steps at least 1 : 2.5 ×5 MAG : 1mV/div to 1V/div in 10 calibrated steps.				
4) Accuracy	normal : ± 3%		magnified : ± 5%		
5) Input impedance	approx. 1M-ohm in parallel with 25pF				
6) Maximum input voltage	Direct : 300V(DC+peak AC), with probe : refer to probe specification				
7) Input coupling	DC - GND - AC				

SPEC.	MODEL	OS-9020A	OS-902RB	OS-9040D	OS-904RD																		
8) Rise time		17.5nS or less(50nS or less : x5 MAG)		8.8nS or less(50nS or less : x5 MAG)																			
9) CH1 out		20mV/div into 50 ohms : DC to 10MHz(-3dB)																					
* Vertical Deflection(2)		CH2 only																					
10) Polarity inversion																							
11) Signal delay		none		delay cable supplied																			
* Horizontal Deflection		A, X-Y	A, A int B, B, B TRIG'D, X-Y																				
1) Display modes		0.2us/div to 0.2S/div in 19 calibrated steps, 1-2-5 sequence, uncalibrated continuous control between steps at least 1 : 2.5																					
2) Time base A		Variable with the holdoff control																					
Hold-off time		none	0.2us/div to 0.2uS/div in 7 calibrated steps 1-2-5 sequence																				
3) Time base B		none	1 div or less 10 div or more																				
Delayed sweep		none	better than 1 : 20000																				
Delay time jitter		10 times(maximum sweep rate : 20nS/div) Note : 50nS/div, 20nS/div of A TIME BASE are uncalibrated.																					
4) Sweep magnification		± 3%, ± 5%(0°C to 50°C), additional error for magnifier ± 2%																					
5) Accuracy																							
* Trigger System		auto, norm, TV-V, TV-H																					
1) Modes		CH1, CH2, LINE, EXT																					
2) Source		AC																					
3) Coupling		+ or -																					
4) Slope																							
5) Sensitivity and Frequency		<table border="1"> <thead> <tr> <th></th> <th>20Hz-2MHz</th> <th>2MHz-20MHz</th> </tr> </thead> <tbody> <tr> <td>INT</td> <td>0.5 div</td> <td>1.5 div</td> </tr> <tr> <td>EXT</td> <td>0.2 Vp-p</td> <td>0.8 Vp-p</td> </tr> </tbody> </table>			20Hz-2MHz	2MHz-20MHz	INT	0.5 div	1.5 div	EXT	0.2 Vp-p	0.8 Vp-p	<table border="1"> <thead> <tr> <th></th> <th>20Hz-2MHz</th> <th>2MHz-40MHz</th> </tr> </thead> <tbody> <tr> <td>INT</td> <td>0.5 div</td> <td>1.5 div</td> </tr> <tr> <td>EXT</td> <td>0.2 Vp-p</td> <td>0.8 Vp-p</td> </tr> </tbody> </table>			20Hz-2MHz	2MHz-40MHz	INT	0.5 div	1.5 div	EXT	0.2 Vp-p	0.8 Vp-p
	20Hz-2MHz	2MHz-20MHz																					
INT	0.5 div	1.5 div																					
EXT	0.2 Vp-p	0.8 Vp-p																					
	20Hz-2MHz	2MHz-40MHz																					
INT	0.5 div	1.5 div																					
EXT	0.2 Vp-p	0.8 Vp-p																					
AUTO, NORM		at least 1 div or 1.0Vp-p																					
TV-V, TV-H		1 M-ohm in pararrall with approx. 30pF																					
6) External trigger		300V(DC + paek AC)																					
Input impedance																							
Max. input voltage																							

SPEC.	MODEL	OS-9020A	OS-902RB	OS-9040D	OS-904RD										
* X-Y Operation 1) X-axis 2) Y-axis 3) X-Y phase defference	(same as CH1 except for the following) Deflection factor : same as that of CH1 Accuracy : $\pm 5\%$ Frequency response : DC to 500KHz(-3dB)														
	same as CH2														
	3° or less (at DC to 50KHz)														
* Readout Function (OS-902RB, OS-904RD only) 1) Cursor readout 2) Panel setting displays 3) Effective cursor range from center graticule 4) Resolution	voltage reference $\Delta V : \Delta - REF$ Time reference $\Delta T : \Delta - REF$ Frequency reference $1/\Delta T : \Delta - REF$ Note : $\Delta V, \Delta T$ changed $\Delta X, \Delta Y$ when the X-Y mode.														
	Vertical axis(CH1, CH2) : V/DIV, UNCAL, MAG (converted value) Note : displayed when the vertical mode is CH1, CH2, DUAL not display when the ADD, B mode Horizontal axis : S/DIV, UNCAL, MAG(converted value)														
	Vertical : within ± 3 div Horizontal : within ± 4 div														
	1/25 div														
	approx. 1KHz frequency, 0.5V($\pm 3\%$)squar wave duty ratio : 50%														
* Power Supply 1) Voltage range 2) Frequency 3) Power consumption	<table border="1"> <thead> <tr> <th>voltage range</th> <th>fuse</th> </tr> </thead> <tbody> <tr> <td>100(90 - 110V)/AC</td> <td>1A250V</td> </tr> <tr> <td>120(108 - 132V)/AC</td> <td>1A250V</td> </tr> <tr> <td>220(198 - 242V)/AC</td> <td>0.5A250V</td> </tr> <tr> <td>240(216 - 250V)/AC</td> <td>0.5A250V</td> </tr> </tbody> </table>					voltage range	fuse	100(90 - 110V)/AC	1A250V	120(108 - 132V)/AC	1A250V	220(198 - 242V)/AC	0.5A250V	240(216 - 250V)/AC	0.5A250V
	voltage range	fuse													
	100(90 - 110V)/AC	1A250V													
120(108 - 132V)/AC	1A250V														
220(198 - 242V)/AC	0.5A250V														
240(216 - 250V)/AC	0.5A250V														
50/60Hz															
approx. 35W		approx. 45W	approx. 45W	approx. 50W											
* Physical Charac. 1) Weight 2) Dimension	5.3Kg	5.5Kg	5.7Kg	6.0Kg											
	320mm(W) \times 140mm(H) \times 430mm(L)														
* Environmental Charac. 1) Temperature range for rated operation 2) Max.abmient operating temperature 3) Max.storage temerature	+10°C to +35°C(+50°F to +95°F)														
	0°C to +40°C(+32°F to +104°F)														
	-20°C to +70°C(-4°F to +158°F)														

SPEC.	MODEL	OS-9020A	OS-902RB	OS-9040D	OS-904RD
4) Humidity range for rated operation		45% to 85% RH			
5) Max.ambient operating humidity		35% to 90% RH			
* Accessories		1) Operation Manual : 1 2) Probes : 2 3) Fuse : 1 4) AC Power Cord : 1			

1-2. PRECAUTIONS

1-2-1. Line Voltage Selection

This instrument must be operated with the correct Line Voltage Selector switch setting and the correct line fuse for the line voltage selected to prevent damage. The instrument operates from either a 90 to 130 volts or a 198 to 250 volt line voltage source. Before line voltage is applied to the instrument, make sure the Line Voltage Selector switch is set correctly.

To change the line voltage selection :

1. Make sure the instrument is disconnected from the power source.
2. Pull out the Line Voltage Selector switch on the rear panel. Select the arrow mark position of the switch from Table 1-1. Slide the arrow mark to the desired position and plug it in.
3. Pull out the Line Fuse Holder containing the fuse for overload protection. Replace the fuse in the holder with the correct fuse from Table 1-1 and plug it in.

Table 1-1. Line Voltage Selection and Fuse Ratings

Line Voltage	Arrow Mark Position	Fuse Ratings
90 to 107 volts	A	2A 125V
108 to 130 volts	B	2A 125V
198 to 230 volts	C	1A 250V
231 to 250 volts	D	1A 250V

1-2-2. Installation and handling precautions

When placing the OS-9000RS in service at your workplace, observe the following precautions for best instrument performance and longest service life.

1. Avoid placing this instrument in an extremely hot or cold place.
Specifically, don't leave this instrument in a close car, exposed to sunlight in midsummer, or next to a space heater.
 2. Don't use this instrument immediately after bringing it in from the cold. Allow time for it to warm to room temperature. Similarly, don't move it from a warm place to a very cold place, as condensation might impair its operation.
 3. Do not expose the instrument to wet or dusty environments.
 4. Do not place liquid-filled containers (such as coffee cups) on top of this instrument. A spill could seriously damage the instrument.
 5. Do not use this instrument where it is subject to severe vibration, or strong blows.
 6. Do not place heavy objects on top of the case, or otherwise block the ventilation holes.
 7. Do not use this oscilloscope in strong magnetic fields, such as near motors.
 8. Do not insert wires, tools, etc. through the ventilation holes.
 9. Do not leave a hot soldering iron near the instrument.
 10. Do not place this scope face down on the ground, or damage to the knobs may result.
 11. Do not use this instrument upright while BNC cables are attached to the rear-panel connectors. This will damage the cable.
 12. Do not apply voltages in excess of the maximum ratings to the input connectors or probes.
-

2. OPERATING INSTRUCTIONS

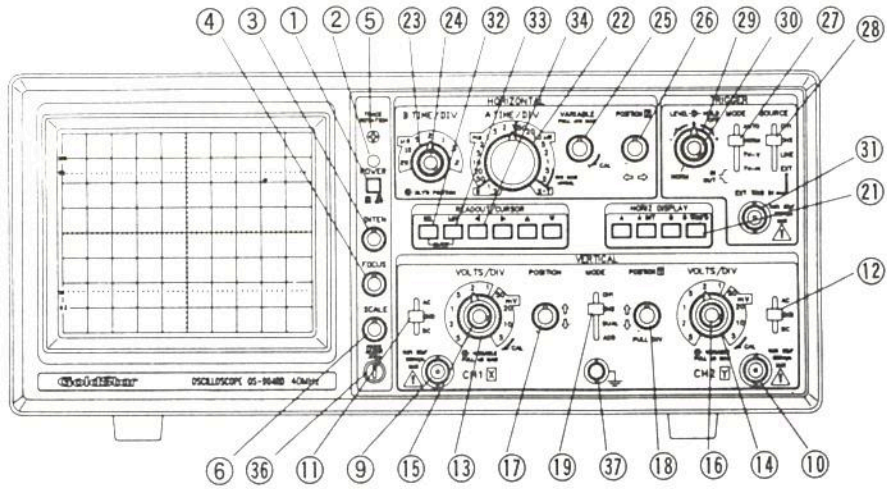

(A) FRONT-PANEL ITEMS

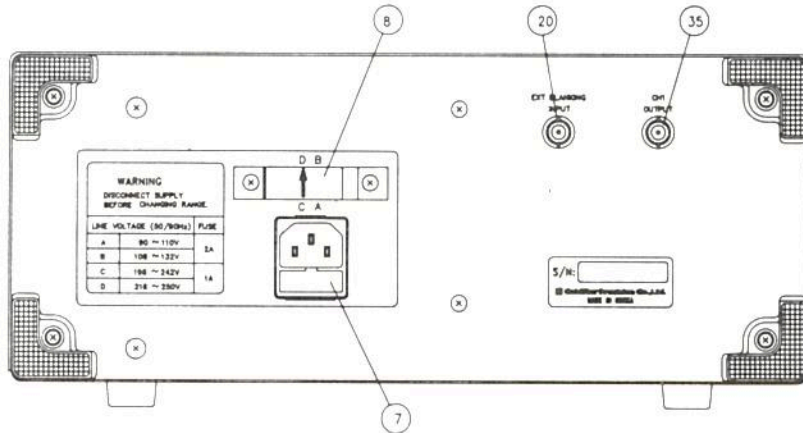

(B) REAR-PANEL ITEMS

- * Note
- ⑥ : only OS-902RB, OS-9040D, OS-904RD
 - ⑳ ㉓ ㉔ : only OS-902RB, OS-9040D, OS-904RD
 - ㉒ ㉓ ㉔ : only OS-902RB, 904RD

Fig.2-1. PANEL ITEMS

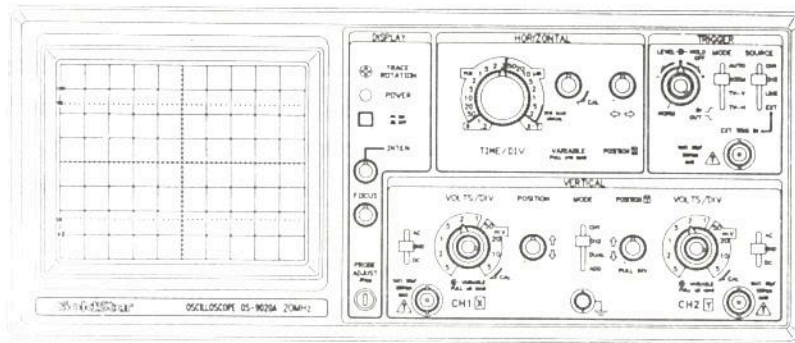

OS-9020A

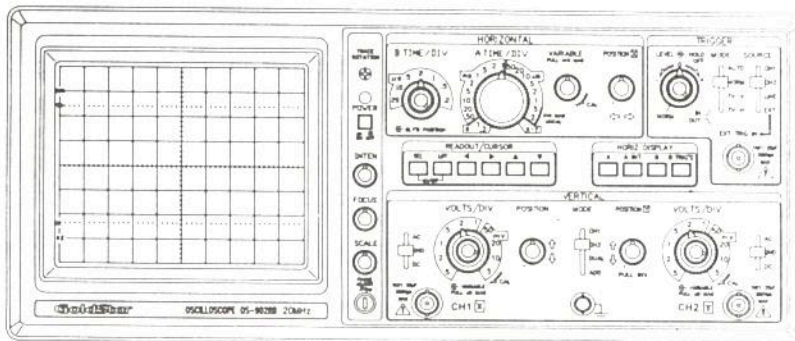

OS-9020B

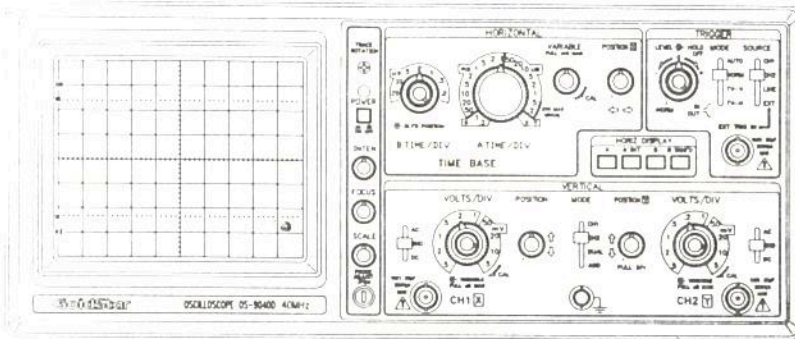

OS-9040D

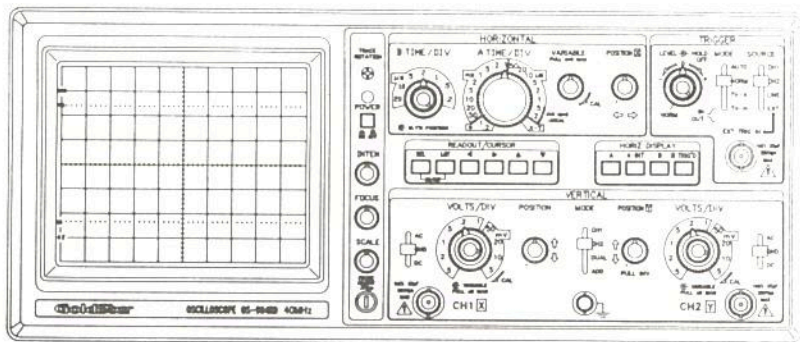

OS-9040RD

Fig.2-2. FRONT VIEWS OF OS-9000SRS

This section contains the information needed to operate the OS-9000SRS and utilize it in a variety of basic and advanced measurement procedures. Included are the identification and function of controls, connectors, and indicators, startup procedures, basic operating routines, and selected measurement procedures.

2-1. FUNCTION OF CONTROLS, CONNECTORS, AND INDICATORS

Before turning this instrument on, familiarize yourself with the controls, connectors, indicators, and other features described in this section. The following descriptions are keyed to the items called out in Figures 2-1 and 2-2.

2-1-1 Display and Power Blocks

<u>Item</u>	<u>Function</u>
(1) POWER switch	Push in to turn instrument power on and off.
(2) POWER lamp	Lights when power is on.
(3) INTEN control	Adjusts the brightness of the CRT display. Clockwise rotation increases brightness.
(4) FOCUS control	To obtain maximum trace sharpness.
(5) ROTATION control	Allows screwdriver adjustment of trace alignment with regard to the horizontal graticule lines of the CRT.
* (6) ILLUM control	To adjust graticule illumination for photographing the CRT display.
(7) Voltage Selector	Permits changing the operating voltage range.
(8) Power Connector	Permits removal or replacement of the AC power cord.

2-1-2 Vertical Amplifier Block

- (9) CH1 or X IN connector
For applying an input signal to vertical-amplifier channel 1, or to the x-axis (horizontal) amplifier during X-Y operation.
- (10) CH2 or Y IN connector
For applying an input signal to vertical-amplifier channel 2, or to the Y-axis (vertical) amplifier during X-Y operation.
- (11) CH1 AC/GND/DC switch
To select the method of coupling the input signal to the CH1 vertical amplifier.
AC position inserts a capacitor between the input connector and amplifier to block any DC component in the input signal.
GND position connects the amplifier to ground instead of the input connector, so a ground reference can be established.
DC position connects the amplifier directly to its input connector, thus passing all signal components on to the amplifier.
- (12) CH2 AC/GND/DC switch
To select the method of coupling the input signal to the CH2 vertical amplifier.
- (13) CH1 VOLTS/DIV switch
To select the calibrated deflection factor of the input signal fed to the CH1 vertical amplifier.
- (14) CH2 VOLTS/DIV switch
To select the calibrated deflection factor of the input signal fed to the CH2 vertical amplifier.
- (15) (16) VARIABLE controls
Provide continuously variable adjustment of deflection factor between steps of the VOLTS/DIV switches. VOLTS/DIV calibrations are accurate only when the VARIABLE controls are click-stopped in their fully clockwise position.
- (15) (16) PULL $\times 5$ MAG switches
(on VARIABLE controls)
To increase the vertical amplifier sensitivity by 5 times. The effective scale factor of the most sensitive position of the VOLTS/DIV switch thereby becomes 1 mV/div.
- (17) CH1 POSITION control
For vertically positioning the CH1 trace on the CRT screen. Clockwise rotation moves the trace up, counterclockwise rotation moves the trace down.
-

- (18) CH2 POSITION control For vertically positioning the CH2 trace on the CRT screen. Clockwise rotation moves the trace upward, counterclockwise rotation moves the trace downward.
- (18) PULL CH2 INV switch
(on CH2 POSITION control) When pulled, the polarity of the CH2 signal is inverted.
- (19) V MODE switch To select the vertical-amplifier display mode.
- CH1 position displays only the channel 1 input signal on the CRT screen.
- CH2 position displays only the channel 2 input signal on the CRT screen.
- DUAL position displays the CH1 and CH2 input signal on the CRT screen simultaneously.
- CHOP mode : TIME/DIV 0.2S~5mS
 ALT mode : TIME/DIV 2mS~0.2 μ s
- ADD position displays the algebraic sum of CH1 & CH2 signals.
- (20) CH1 OUTPUT connector Provides amplified output of the channel 1 signal suitable for driving a frequency counter or other instrument.
-

2-1-3 Sweep and Trigger Blocks

- * (21) HORIZ DISPLAY switches
- To select the sweep mode.
- A pushbutton sweeps the CRT at the main (A) timebase rate when pressed.
- A INT pushbutton sweeps the CRT at the main (A) timebase rate when pressed, and the B timebase intensifies a section of the trace(s). The location of the intensified section is determined by the DELAY TIME POS control.
- B pushbutton sweeps the CRT at the rate selected by the B TIME/DIV switch, after a delay determined by the A TIME/DIV switch and the DELAY TIME POS control.
- B TRIG'D pushbutton sweeps the CRT at the rate selected by the B TIME/DIV switch when triggered by the first trigger pulse occurring after the delay time determined by the A TIME/DIV switch and the DELAY TIME POS control.
- (22) A TIME/DIV switch
- To select either the calibrated sweep rate of the main (A) timebase, the delay-time range for delayed-sweep operation, or X-Y operation.
- * (23) B TIME/DIV switch
- To select the calibrated sweep rate of the delayed (B) timebase.
- * (24) DELAY TIME POS control
- To determine the exact starting point within the A timebase delay range at which the B timebase will begin sweeping.
- (25) A VARIABLE control
- Provides continuously variable adjustment of sweep rate between steps of the A TIME/DIV switch. TIME/DIV calibrations are accurate only when the A VARIABLE control is click-stopped fully clockwise.
- (25) PULL $\times 10$ MAG switch
(on A VARIABLE control)
- To expand the horizontal deflection by 10 times, thus increasing horizontal sensitivity by 10 times for X-Y operation, and increasing the effective sweep speed by 10 times.
- (26) Horizontal POSITION control
- To adjust the horizontal position of the traces displayed on the CRT. Clockwise rotation moves the traces to the right, counterclockwise rotation moves the traces to the left.
-

(27) Trigger MODE switch

To select the sweep triggering mode.

AUTO position selects free-running sweep where a baseline is displayed in the absence of a signal. This condition automatically reverts to triggered sweep when a trigger signal of 25 Hz or higher is received and other trigger controls are properly set.

NORM position produces sweep only when a trigger signal is received and other controls are properly set. No trace is visible if any trigger requirement is missing. This mode must be used when the signal frequency is 25 Hz or lower.

TV-V position is used for observing a composite video signal at the frame rate.

TV-H position is used for observing a composite video signal at the line rate.

(28) Trigger SOURCE switch

To conveniently select the trigger source.

CH1 position selects the channel 1 signal as the trigger source.

CH2 position selects the channel 2 signal as the trigger source.

LINE position selects a trigger derived from the AC power line. This permits the scope to stabilize display line-related components of a signal even if they are very small compared to other components of the signal.

EXT position selects the signal applied to the EXT TRIG IN connector.

- (29) HOLDOFF control
Allows triggering on certain complex signals by changing the holdoff (dead) time of the main (A) sweep. This avoids triggering on intermediate trigger points within the repetition cycle of the desired display. The holdoff time increases with clockwise rotation.
NORM is a position at full counterclockwise rotation that is used for ordinary signals.
- (30) Trigger LEVEL control
To select the trigger-signal amplitude at which triggering occurs. When rotated clockwise, the trigger point moves toward the positive peak of the trigger signal. When this control is rotated counterclockwise, the trigger point moves toward the negative peak of the trigger signal.
- (30) Trigger SLOPE switch
(on LEVEL control)
To select the positive or negative slope of the trigger signal for initiating sweep. Pushed in, the switch selects the positive (+) slope. When pulled, this switch selects the negative (-) slope.
- (31) EXT TRIG IN connector
For applying external trigger signal to the trigger circuits.

2-1-4. Readout function Block

* (32) Cursor SElect switch

This switch has the function of changing the cursor selection mode, such as reference cursor (X), Delta cursor (+) and tracking cursor (X, +) The selected cursor is displayed brighter than the other.

* (33) $1/\Delta T$ switch

This switch changes the measurement mode such as ΔT or $1/\Delta T$.

* (32),(33) Readout ON/OFF switch

Readout OFF function can be achieved by pushing these two switches simultaneously. And by pushing again readout function is restored.

* (34) Cursor movement switches (\blacktriangleleft , \blacktriangleright , \blacktriangleup , \blacktriangledown)

By pushing these switches, the selected cursor can be moved to any position.

2-1-5. Miscellaneous Features

- | | |
|-----------------------------------|--|
| (35) EXT BLANKING INPUT connector | For applying signal to intensity modulate the CRT. Trace brightness is reduced with a positive signal, and increased with a negative signal. |
| (36) CAL connector | Provides a fast-rise square wave of precise amplitude for probe adjustment and vertical amplifier calibration. |
| (37) Ground connector | Provides an attachment point for a separate ground lead. |

2-2. BASIC OPERATING PROCEDURES

The following paragraphs in this section describe how to operate the OS-9000SRS, beginning with the most elementary operating modes, and progressing to the less frequently-used and/or complex modes.

2-2-3. Preliminary Control Settings and Adjustments

Before placing the instrument in use, set up and check the instrument as follows :

1. Set the following controls as indicated.

POWER switch (1)	OFF (released)
INTEN control (3)	Fully CCW
FOCUS control (4)	Mid rotation
AC/GND/DC switches (11) (12)	AC
VOLTS/DIV switches (13) (14)	20 mV
Vertical POSITION controls (17) (18)	Mid rotation and pushed in
VARIABLE controls (15) (16)	Fully CW and pushed in
V MODE switch (19)	CH1
HORIZ DISPLAY switches (21)	A
A TIME/DIV switch (22)	.5 mS
A VARIABLE control (25)	Fully CW and pushed in
Horizontal POSITION control (26)	Mid rotation
Trigger MODE switch (27)	AUTO
Trigger SOURCE switch (28)	CH1
Trigger LEVEL control (30)	Mid rotation
HOLDOFF control (29)	NORM (Fully CCW)

2. Connect the AC Power Cord to the Power Connector (8), then plug the cord into a convenient AC outlet.

3. Press in the POWER switch (1). The POWER lamp (2) should light immediately. About 30 seconds later, rotate the INTEN control clockwise until the trace appears on the CRT screen. Adjust brightness to your liking.

CAUTION : A burn-resistant material is used in the CRT. However if the CRT is left with an extremely bright dot or trace for a very long time, the screen may be damaged. Therefore, if a measurement requires high brightness, be certain to turn down the INTEN control immediately afterward. Also, get in the habit of turning the brightness way down if the scope is left unattended for any period of time.

4. Turn the FOCUS control (4) for a sharp trace.
 5. Turn the CH1 Vertical POSITION control (19) to move the CH1 trace to the center horizontal graticule line.
 6. See if the trace is precisely parallel with the graticule line. If it is not, adjust the ROTATION control (5) with a small screwdriver.
 7. Turn the Horizontal POSITION control (26) to align the left edge of the trace with the left-most graticule line.
 8. Set one of the supplied probes for $10\times$ attenuation. Then, connect its BNC end to the CH1 or X IN connector (9) and its tip to the CAL connector (36). A square-wave display, two and a half divisions in amplitude, should appear on the CRT screen.
 9. If the tops and bottoms of the displayed square waves are tilted or peaked, the probes must be compensated (matched to the scope input capacitance). Adjust the capacitance correction trimmer of the probe with a small screwdriver. See Figure 2-3.
 10. Set the V MODE switch (19) to CH2, and perform Steps 8 and 9 with the other probe on channel 2.
-

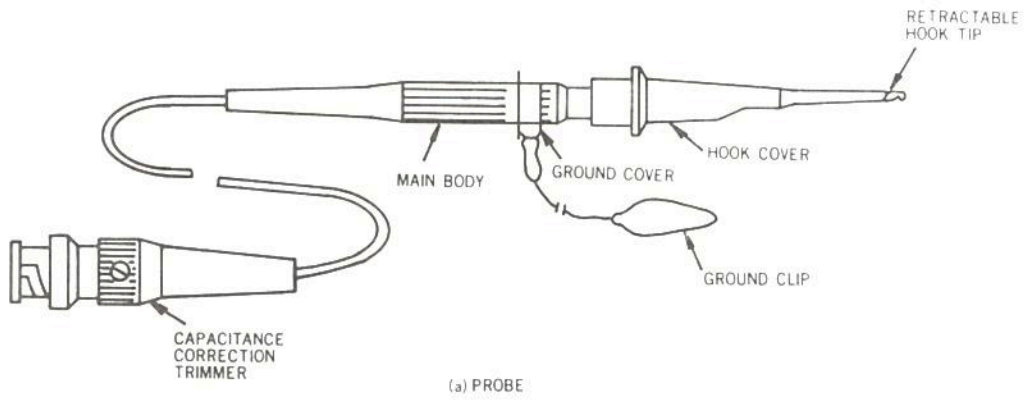

(a) PROBE

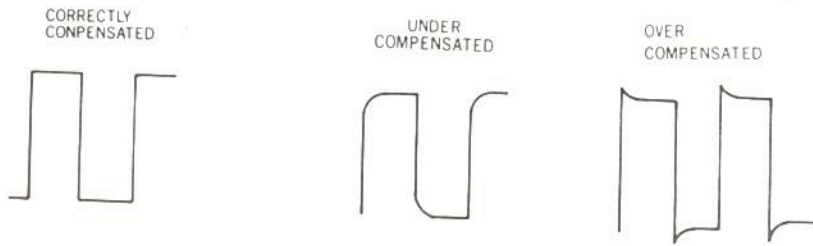

(b) EFFECTS OF PROBE COMPENSATION

FIGURE 2-3. PROBE COMPENSATION

2-2-2 Signal Connections

There are three methods of connecting an oscilloscope to the signal you wish to observe. They are : a simple wire lead, coaxial cable, and scope probes.

A simple lead wire may be sufficient when the signal level is high and the source impedance low (such as TTL circuitry), but is not often used. Unshielded wire picks up hum and noise ; this distorts the observed signal when the signal level is low. Also, there is the problem of making secure mechanical connection to the input connectors. A binding post-to BNC adapter is advisable in this case.

Coaxial cable is the most popular method of connecting an oscilloscope to signal sources and equipment having output connectors. The outer conductor of the cable shields the central signal conductor from hum and noise pickup. These cables are usually fitted with BNC connectors on each end, and specialized cable and adaptors are readily available for mating with other kinds of connectors.

Scope probes are the most popular method of connecting the oscilloscope to circuitry. These probes are available with $1\times$ attenuation (direct connection) and $10\times$ attenuation. The $10\times$ attenuator probes increase the effective input impedance of the probe/scope combination to 10 megohms shunted by a few picofarads. The reduction in input capacitance is the most important reason for using attenuator probes at high frequencies, where capacitance is the major factor in loading down a circuit and distorting the signal. When $10\times$ attenuator probes are used, the scale factor (VOLTS/DIV switch setting) must be multiplied by ten.

Despite their high input impedance, scope probes do not pick up appreciable hum or noise. As was the case with coaxial cable, the outer conductor of the probe

cable shields the central signal conductor. Scope probes are also quite convenient from a mechanical standpoint.

To determine if a direct connection with shielded cable is permissible, you must know the source impedance of the circuit you are connecting to, the highest frequencies involved, and the capacitance of the cable. If any of these factors are unknown, use a 10× low-capacitance probe.

An alternative connection method at high frequencies is terminated coaxial cable. A feed-thru terminator having an impedance equal to that of the signal-source impedance is connected to the oscilloscope input connector. A coaxial cable of matching impedance connects the signal source to the terminator. This technique allows using cables of nearly any practical length without signal loss.

If a low-resistance ground connection between oscilloscope and circuit is not established, enormous amounts of hum will appear in the displayed signal. Generally, the outer conductor of shielded cable provides the ground connection. If you are using plain lead wire, be certain to first connect a ground wire between the OS-9000SRS Ground connector (39) and the chassis or ground bus of the circuit under observation.

WARNING : The OS-9000SRS have an earth-grounded chassis (via the 3-prong power cord). Be certain the device to which you connect the scope is transformer operated. Do NOT connect this oscilloscope or any other test equipment to "AC/DC", "hot chassis", or "transformerless" devices. Similarly, do NOT connect this scope directly to the AC power line or any circuitry connected directly to the power line. Damage to the instrument and severe injury to the operator may result from failure to heed this warning.

2-2-3. Single-trace Operation

Single-trace operation with single timebase and internal triggering is the most elementary operating mode of the OS-9000SRS. Use this mode when you wish to observe only a single signal, and not be disturbed by other traces on the CRT. Since this is fundamentally a two-channel instrument, you have a choice for your single channel. Channel 1 has an output terminal; use channel 1 if you also want to measure frequency with a counter while observing the waveform. Channel 2 has a polarity-inverting switch. While this adds flexibility, it is not too useful in ordinary single-trace operation.

The OS-9000SRS is set up for single-trace operation as follows:

1. Set the following controls as indicated below. Note that the trigger source selected (CH1 or CH2 SOURCE) must match the single channel selected (CH1 or CH2 V MODE).

POWER switch (1)	ON (pushed in)
AC/GND/DC switches (11) (12)	AC
Vertical POSITION controls (17) (18)	Mid rotation and pushed in
VARIABLE controls (15) (16)	Fully CW and pushed in
V MODE switch (19)	CH1 (CH2)
HORIZ DISPLAY switches (21)	A
A VARIABLE control (22)	Fully CW and pushed in
Trigger MODE switch (27)	AUTO
Trigger SOURCE switch (28)	CH1 (CH2)
Trigger LEVEL control (30)	Mid rotation
HOLDOFF control (29)	NORM (fully CCW)

2. Use the corresponding Vertical POSITION control (17) or (18) to set the trace near mid screen.
3. Connect the signal to be observed to the corresponding IN connector (9) or (10), and adjust the corresponding VOLTS/DIV switch (13) or (14) so the displayed signal is totally on screen.

CAUTION; Do not apply a signal
greater than 300 V (DC + peak AC)

4. Set the A TIME/DIV switch (22) so the desired number of signal cycles are displayed. For some measurements just 2 or 3 cycles are best; for other measurements 50-100 cycles appearing like a solid band works best. Adjust the Trigger LEVEL control (30) if necessary for a stable display.
-

5. If the signal you wish to observe is so weak that even the 5 mV position of the VOLTS/DIV switch cannot produce sufficient trace height for triggering or a useable display, pull the corresponding VARIABLE control knob (PULL $\times 5$ MAG switch) (15) or (16). This produces 2 mV/div sensitivity when the VOLTS/DIV switch is set to 10 mV, and 1 mV/div when it is set to 5 mV. However, the channel bandwidth decreases to 7 MHz, and the trace noise may become noticeable when this is done.
6. If the signal you wish to observe is so high in frequency that even the .2 μ S position of the A TIME/DIV switch results in too many cycles displayed, pull the A VARIABLE knob to activate the PULL $\times 10$ MAG switch (25). This increases the effective sweep speed by a factor of ten, so .2 μ S becomes 20 nS/div, .5 μ S become 50 nS/div, etc. 0.2 and 0.5 μ S MAG are uncalibrated, 1 μ S is calibrated and below.
7. If the signal you wish to observe is either DC or low enough in frequency that AC coupling attenuates or distorts the signal, flip the AC/GND/DC switch (11) or (12) to DC.

CAUTION : If the observed waveform is
low-level AC, make certain it is not
riding on a high-amplitude DC voltage.

You will also have to reset the Trigger MODE switch (27) to NORM if the signal frequency is below 25 Hz, and possibly readjust the Trigger LEVEL control (30).

2-2-4. Dual-trace Operation

Dual-trace operation is the major operating mode of the OS-9000SRS. The setup for dual-trace operation is identical to that of 2-3-2 Single-trace Operation with the following exceptions :

1. Set the V MODE switch (19) to either ALT or CHOP. Select ALT for relatively high-frequency signals (A TIME/DIV switch set to .2mS or faster). Select CHOP for relatively low-frequency signals (A TIME/DIV switch set to .5 mS or slower)
 2. If both channels are displaying signals of the same frequency, set the Trigger SOURCE switch (28) to the channel having the steepest-slope waveform. If the signals are different but harmonically related, trigger from the channel carrying the lowest frequency. Also, remember that if you disconnect the channel serving as the trigger source, the entire display will free run.
-

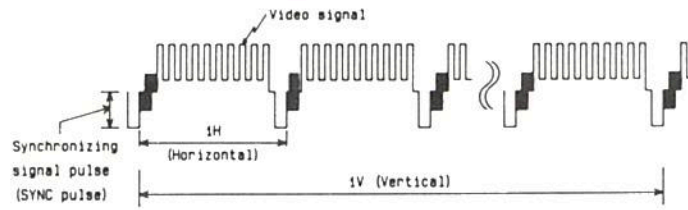

(a) composite video

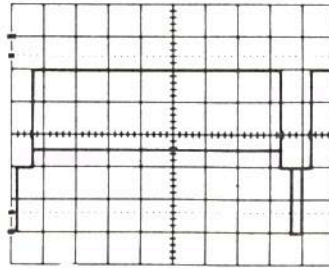

(b) TV-V coupling

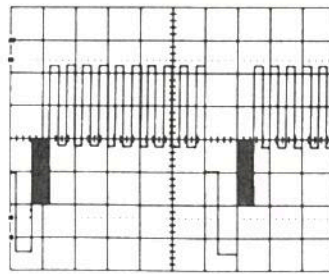

(c) TV-H coupling

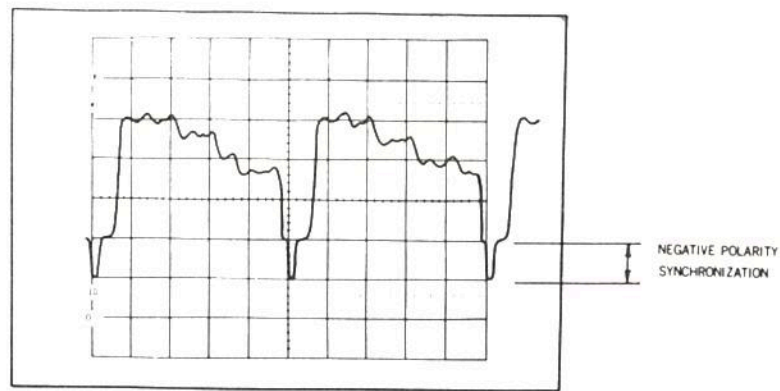

(d) sync polarity

FIGURE 2-4. USING THE TV SYNC SEPARATOR

2-2-5. Trigger options

Triggering is often the most difficult operation to perform on an oscilloscope because of the many options available and the exacting requirements of certain signals.

Trigger Mode Selection. When the NORM trigger mode is selected, the CRT beam is not swept horizontally across the face of the CRT until a sample of the signal being observed, or another signal harmonically related to it, triggers the timebase. However, this trigger mode is inconvenient because no baseline appears on the CRT screen in the absence of a signal, or if the trigger controls are improperly set. Since an absence of trace can also be due to an improperly-set Vertical POSITION control or VOLTS/DIV switch, much time can be wasted in determining the cause. The AUTO trigger mode solves this problem by causing the timebase to automatically free run when not triggered. This yields a single horizontal line with no signal, and a vertically-deflected but non-synchronized display when vertical signal is present but the trigger controls are improperly set. This immediately indicates what is wrong. The only hitch with AUTO operation is that signals below 25 Hz cannot, and complex signals of any frequency may not, reliably trigger the timebase. Therefore, the usual practice is to leave the Trigger MODE switch (27) set to AUTO, but reset it to NORM if any signal (particularly one below 25 Hz) fails to produce a stable display.

The TV-V and TV-H positions of the Trigger MODE switch insert a TV sync separator into the trigger chain, so a clean trigger signal at either the vertical or horizontal-repetition rates can be removed from a composite video signal (Figure 2-4a). To trigger the scope at the vertical rate (Figure 2-4b), set the Trigger MODE switch to TV-V. To trigger the scope at the horizontal (line) rate (Figure 2-4c), set the Trigger MODE switch to TV-H. For best results, the TV sync polarity should be negative (Figure 2-4d) when the sync separator is used.

Trigger Point Selection. The SLOPE switch determines whether the sweep will on a positive-going or negative-going transition of the trigger signal. (See Figure 2-5). Always select the steepest and most stable slope or edge. For example, small changes in the amplitude of the sawtooth shown in Figure 2-5A will cause jittering if the timebase is triggered on the positive (ramp) slope, but have no effect if triggering occurs on the negative slope (a fast-fall edge). In the example shown in Figure 2-5B, both leading and trailing edges are very steep (fast rise and fall times). However, triggering from the jittering trailing edge will cause the entire trace to jitter, making observation difficult. Triggering from the stable leading edge (+ slope) yields a trace that has only the trailing-edge jitter of the original signal. If you are ever in doubt, or have an unsatisfactory display, try both slopes to find the best way.

Trigger LEVEL control. The LEVEL control determines the point on the selected slope at which the main (A) timebase will be triggered. The effect of the LEVEL control on the displayed trace is shown in Figure 2-5C. The +, 0, and - panel markings for this control refer to the waveform's zero crossing and points more positive(+) and more negative (-) than this. If the trigger slope is very steep, as with square waves or digital pulses, there will be no apparent change in the displayed trace until the LEVEL control is rotated past the most positive or most negative trigger point, whereupon the display will free run (AUTO sweep mode) or disappear completely (NORM sweep mode). Try to trigger at the mid point of slow-rise waveforms (such as sine and triangular waveforms), since these are usually the cleanest spots on such waveforms.

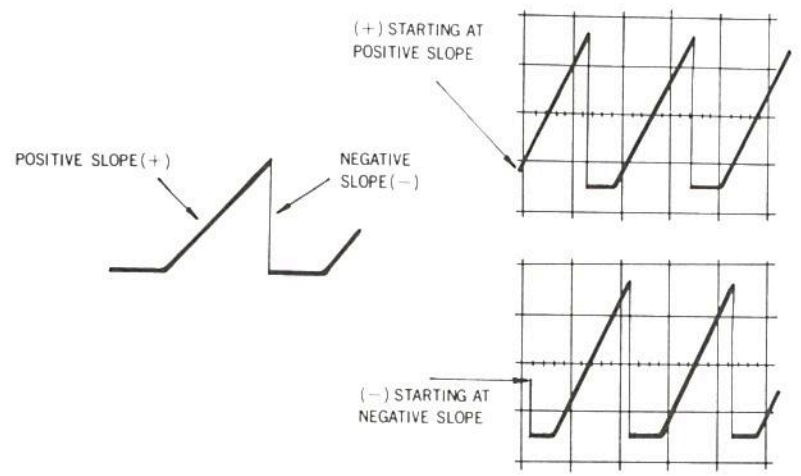

a. SAWTOOTH WAVEFORM

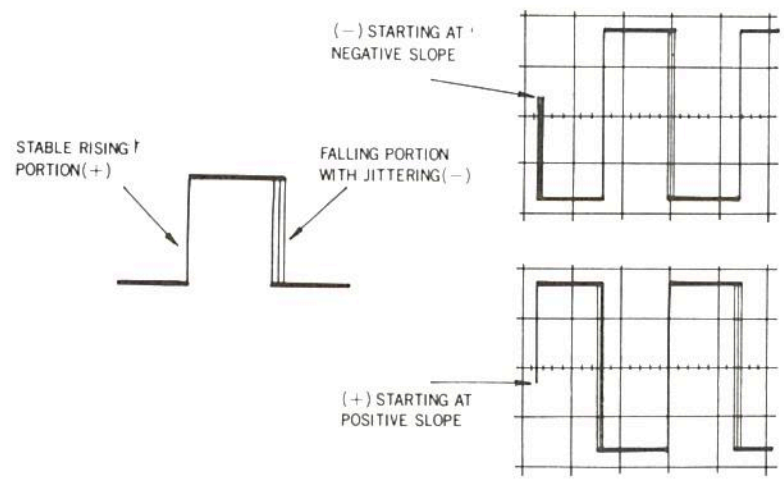

b. SQUARE WAVEFORM

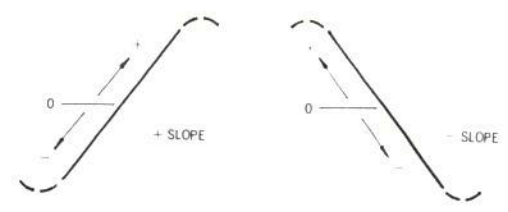

c. TRIGGER LEVEL

FIGURE 2-5. TRIGGER-SLOPE SELECTION

2-2-6. Additive and Differential Operation

Additive and differential operation are forms two-channel operation where two signals are combined to display one trace. In additive operation, the resultant trace represents the algebraic sum of the CH1 and CH2 signals. In differential operation, the resultant trace represents the algebraic difference between the CH1 and CH2 signals.

To set up the OS-9000SRS for additive operation, proceed as follows :

1. Set up for dual-trace operation per paragraph 2-3-3 Dual-trace Operation.
2. Make sure both VOLTS/DIV switches (13) and (14) are set to the same position and the VARIABLE controls (15) and (16) are click-stopped fully clockwise. If the signal levels are very different, set both VOLTS/DIV switches to the position producing a large on-screen display of the highest-amplitude signal.
3. Trigger from the channel having the biggest signal.
4. Set the V MODE switch to ADD position. Then, the single trace resulting is the algebraic sum of the CH1 and CH2 signals. Either of both of the Vertical POSITION controls (19) and (20) can be used to shift the resultant trace.

NOTE : If the input signals are in-phase,
the amplitude of the resultant trace will
be the arithmetic sum of the individual
traces (eg., 4.2 div + 1.2 div = 5.4 div)
If the input signals are 180° out-of-phase,
the amplitude will be the difference(eg.,
4.2 div - 1.2 div = 3.0 div.)

5. If the p-p amplitude of the resultant trace is very small, turn both VOLTS/DIV switches to increase the display height. Make sure both are set to the same position.

To set up the OS-9000SRS for differential operation do everything just described and also pull the CH2 Vertical POSITION knob (20) to activate the PULL CH2 INV switch. The single trace resulting is the algebraic difference of the CH1 and CH2 signals. Now if the input signals are in-phase, the amplitude of the resultant trace is the arithmetic difference of the individual traces (eg., 4.2 div - 1.2 div = 3.0 div.) If the input signals are 180 out-of-phase, the amplitude of the resultant trace is the arithmetic sum of the individual traces (eg., 4.2 div + 1.2 div = 5.4 div)

2-2-7 X-Y Operation

The internal timebase of the OS-9000SRS are not utilized in X-Y operation ; deflection in both the vertical and horizontal directions is via external signals. Vertical channel 1 serves as the X-axis (horizontal) signal processor, so horizontal and vertical axes have identical control facilities.

All of the V MODE, and trigger switches, as well as their associated controls and connectors, are inoperative in the X-Y mode.

To set up the OS-9000SRS for X-Y operation, proceed as follows ;

1. Turn the A TIME/DIV switch (22) fully clockwise to its X-Y positions.

CAUTION : Reduce the trace intensity,
lest the undeflected spot damage the
CRT phosphor.

2. Apply the vertical signal to the CH2 or Y IN connector (10), and the horizontal signal to the CH1 or X IN connector(9). Once the trace is deflected, restore normal brightness.
 3. Adjust the trace height with the CH2 VOLTS/DIV switch (14). and the trace width with the CH1 VOLTS/DIV SWITCH (13). The PULL $\times 5$ MAG switches(15) and (16) on the VARIABLE controls can be used if greater is necessary, so leave the TIME VARIABLE control (25) knob pushed in.
 4. Adjust the trace position vertically (Y axis) with the CH2 Vertical POSITION control (18). Adjust the trace position horizontally (X axis) with the Horizontal POSITION control (26) ; the CH1 Vertical POSITION control has no effect during X-Y operation.
 5. The vertical (Y-axis) signal can be inverted by pulling the CH2 Vertical POSITION knob to activate the PULL CH2 INV switch (18).
-

2-2-8. Delayed-time base Operaton(only OS-902RB, OS-9040D, OS-904RD)

The OS-9000SRS(except OS-9020A) contains two timebases, arranged so one (the A timebase) may provide a delay between a trigger event and the beginning of sweep by the second (B) timebase. This allows any selected portion of a waveform, or one pulse of a pulse train, to be spread over the entire CRT screen. Delayed sweep can be used with either single-trace or dual-trace operation. The procedure is the same regardless of the number of traces displayed.

Basic Delayed Sweep. For delayed sweep, proceed as follows :

1. Set up the instrument for whatever vertical mode you desire.
2. Make sure the B TRIG'D pushbutton (21) is out.
3. Press the A INT HORIZ DISPLAY pushbutton (21). A section of the trace(s) will brighten.

NOTE : The intensified portion will be quite small if there is a large difference between the setting of the A and B TIME/DIV switches.

4. Turn the B TIME/DIV switch (23) until the intensified portion of the trace widens to an amount equal to the portion of the trace you wish to magnify (see Figure 2-6b).
5. Turn the DELAY TIME POS control (24) to position the intensification over the portion of the trace you wish to magnify.
6. Press the B HORIZ DISPLAY pushbutton (21). That portion of the trace intensified in Step 5 now appears spread over the full width of the CRT screen. The trace now displayed is being swept by the B timebase (Figure 2-6c).
7. If needed, additional enlargement is possible by pulling the A VARIABLE knob (25) for PULL $\times 10$ MAG.

Triggered B Sweep. In basic delayed sweep, the B timebase is not triggered by a signal event, it begins when the main (A timebase) sweep crosses compare level setting by DLY TIME POS. knob. The only problem with this is that main timebase jitter becomes apparent in the B sweep at high ratios of A to B TIME/DIV switch settings (100 : 1 and up). To circumvent this, the B sweep can be triggered by the signal itself, or a time-related trigger signal. The DELAY TIME POS control then determines the minimum delay time between A and B sweeps; the actual delay time will be that plus the additional time until the next available trigger. The result is that actual delay time is variable only with step resolution, in increments of the interval between triggers. The maximum magnification possible by this technique is several thousand times. CRT brightness being the limiting factor.

For triggered B sweep, proceed as follows :

1. Set up the scope for basic delayed sweep as described in the preceding paragraphs.
2. Press in the B TRIG'D pushbutton (21), and adjust the Trigger LEVEL control (30) if necessary. The B timebase is now triggering on the same trigger signal as the A timebase. The start of B sweep will always be a leading or trailing edge of the trigger signal; turning the DELAY TIME POS control will not change this.

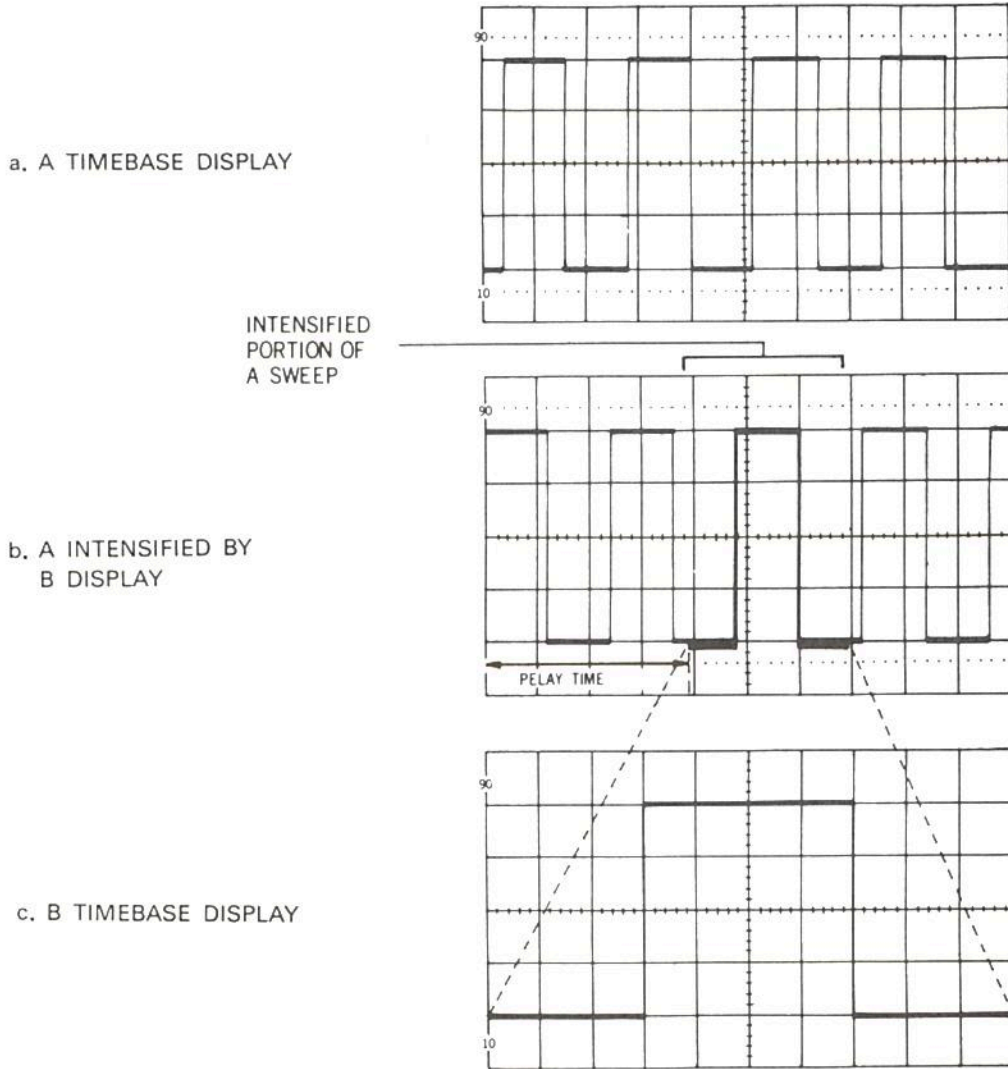

FIGURE 2-6. SWEEP MAGNIFICATION BY THE B TIME BASE
(only OS-902RB, OS-9040D, OS-904RD)

2-2-9. Read out Operation (only OS-902RB, OS-904RD)

The first things to do are as follows.

- Bring the brightness and FOCUS at optimum positions for easy read out.
- Display the waveform as large as possible to minimize the read error.
- Check the capacity correction when using a probe. (Refer to paragraph (1) 'When using a probe' of Section 8 'Method for connecting signals' for the method for correcting capacity.)

(1) Set value display

The following set values are displayed when the vertical mode is not ADDED, and the readout function is ON.

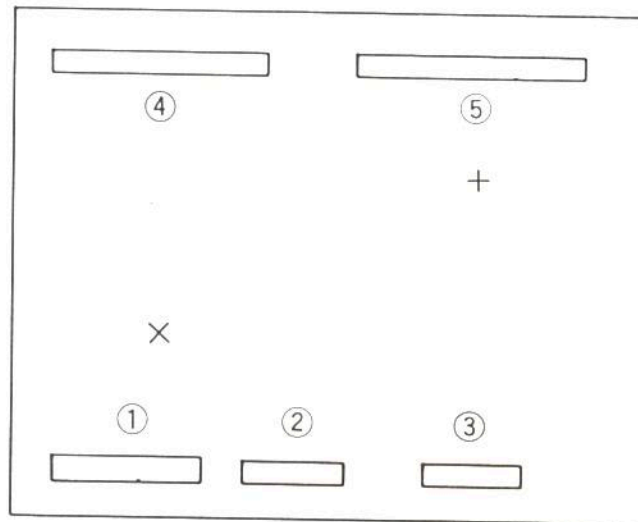

① CH1 or CH2 displays

Set values of CH1 VOLTS/DIV are displayed when the vertical mode is CH1, ALT or CHOP. And the values are altered to CH2 VOLTS/DIV when the vertical mode is CH2.

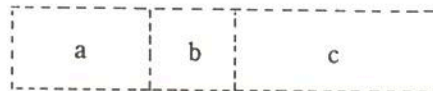

- a. The vertical mode is displayed when the mode is CH1 or CH2. When the vertical mode is ALT or CHOP and b and c information of CH1 are displayed from here.

CH1	: CH1
CH2	: CH2

- b. $\times 5$ GAIN : MG
V/DIV UNCAL : \rangle
Normal state : Blank
Note : MG is displayed prior to \rangle .

- c. V/DIV : 1mV to 5V

② CH2 display

The values of CH2 VOLTS/DIV are displayed when vertical mode is ALT or CHOP. This part is not displayed when the vertical mode is CH1 and CH2.



- a. $\times 5$ MAIN : MG
V/DIV UNCAL : \rangle
Normal state : Blank

- b. V/DIV : 1mV to 5V

③ TIME display

The sweep time is displayed, or 'X-Y' is displayed when the TIME/DIV select switch is set to the position of X-Y.



- a. $\times 10$ GAIN : MG
TIME/DIV UNCAL : \rangle
Normal state : Blank
or X-Y mode

- b. TIME/DIV : 20nS to 0.2S
X-Y mode : X-Y

④ ΔV cursor measurement value display



- a. CH1, ALT, CHOP : $\Delta V1$
-

CH2 : $\Delta V2$
 X-Y : ΔX

b. Measurement signed value display

$\Delta V1, \Delta V2$: 0.00mV to 38.0V
 ΔX : 0.00mV to 48.0V

Note : When the REF(\times) cursor is above the $\Delta(+)$ cursor on the screen, the polarity display is ($-$), otherwise the polarity ($+$) is not displayed.

When the VOLTS/DIV variable is set to the uncalibrated position 'UNCAL' is displayed.

⑤ ΔT cursor measurement value display



a. ΔT : ΔT
 $1/\Delta T$: $1/\Delta T$
 X-Y : ΔT

b. Measurement signed value display

ΔT : 0.0nS to 1.920S
 $1/\Delta T$: 0.521Hz to 40MHz
 X-Y : 0.00mV to 38.9V

Note : When the REF(\times) cursor is on the right of the $\Delta(+)$ cursor on the screen, the polarity display is ($-$) otherwise the polarity ($+$) is not displayed.

When $1/\Delta T$ mode, the polarity is not displayed always. If the difference is zero, '---' meaning 'Undefined frequency', is displayed, and when the frequency is higher than 40MHz, '>40MHz' is displayed.

When the SWP VAR control (or VOLTS/DIV select switch when X-Y mode) is set to the uncalibrated position 'UNCAL' is displayed.

2-3. MEASUREMENT APPLICATIONS

This section contains instructions for using your OS-9000SRS for specific measurement procedures. However, this is but a small sampling of the many applications possible for this oscilloscope. These particular applications were selected to demonstrate certain controls and features not fully covered in BASIC OPERATING PROCEDURES, to clarify certain operations by example, or for their importance and universality.

2-3-1. Amplitude Measurements

The modern triggered sweep oscilloscope has two major measurement functions. The first of these is amplitude. The oscilloscope has an advantage over most other forms of amplitude measurement in that complex as well as simple waveforms can be totally characterized (i.e., complete voltage information is available).

Oscilloscope voltage measurement generally fall into one of two types : peak-to-peak or instantaneous peak-to-peak (p-p) measurement simply notes the total amplitude between extremes without regard to polarity reference. Instantaneous voltage measurement indicates the exact voltage from each every point on the waveform to a ground reference. When making either type of measurement, make sure that the VARIABLE controls are click-stopped fully clockwise.

Peak-to-Peak Voltages. To measure peak-to-peak voltage, proceed as follows.

1. Set up the scope for the vertical mode desired per the instructions in 2-3 BASIC OPERATING PROCEDURES.
2. Adjust the TIME/DIV switch (22) or (23) for two or three cycles of waveform, and set the VOLTS/DIV switch for the largest-possible totally-on-screen display.
3. Use the appropriate Vertical POSITION control (17) or (18) to position the negative signal peaks on the nearest horizontal graticule line below the signal peaks, per Figure 2-7.
4. Use the Horizontal POSITION control (26) to position one of the positive peaks on the central vertical graticule line. This line has additional calibration marks equal to 0.2 major division each.
5. Count the number of division from the graticule line touching the negative signal peaks to the intersection of the positive signal peak with the central vertical graticule line. Multiply this number by the VOLTS/DIV switch setting to get the peak-to-peak voltage of the waveform. For example, if the VOLTS/DIV switch were set to 2V, the waveform shown in Figure 2-7 would be 8.0V p-p ($4.0 \text{ div} \times 2V$).
6. If $\times 5$ vertical magnification is used, divide the Step 5 voltage by 5 to get the correct p-p voltage. However if $10\times$ attenuator probes are used, multiply the voltage by 10 to get the correct p-p voltage.
7. If measuring a sine wave below 100 Hz, or a rectangular wave below 1000Hz, flip the AC/GND/DC switch to DC.

CAUTION : Make certain the waveform is not riding
on a higher-amplitude DC voltage.

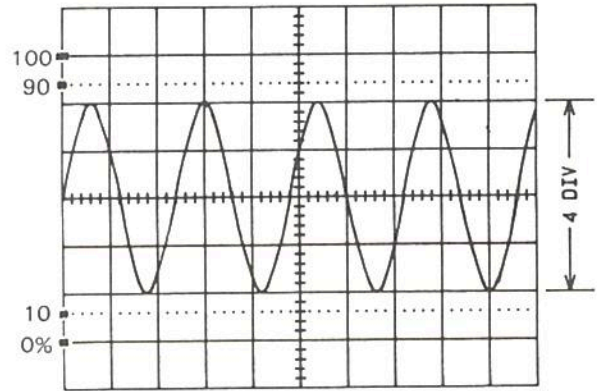

FIGURE 2-7. PEAK-TO-PEAK VOLTAGE MEASUREMENT

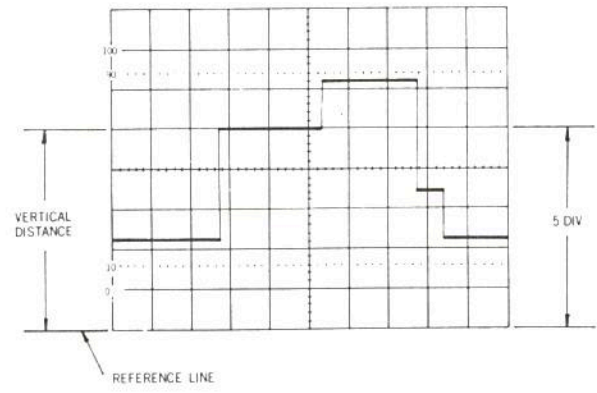

FIGURE 2-8. INSTANTANEOUS VOLTAGE MEASUREMENTS

Instantaneous Voltages. To measure instantaneous voltage, proceed as follows.

1. Set up the scope for the vertical mode desired per the instructions in 2-3 BASIC OPERATING PROCEDURES.
2. Adjust the TIME/DIV switch (22) or (23) for one complete cycle of waveform and set the VOLTS/DIV switch for a trace amplitude of 4 to 6 divisions (see Figure 2-8)
3. Flip the AC/GND/DC switch (11) or (12) to GND.
4. Use the appropriate Vertical POSITION control (17) or (18) to set the baseline on the central horizontal graticule line. However, if you know the signal voltage is wholly positive, use the bottommost graticule line. If you know the signal voltage is wholly negative, use the uppermost graticule line.

NOTE : The Vertical POSITION controls must not be touched again until the measurement is completed.

5. Flip the AC/GND/DC switch to DC. The polarity of all points above the ground-reference line is positive ; all points below the ground-reference line are negative.

CAUTION : Make certain the waveform is not riding on a high-amplitude DC voltage before flipping the AC/GND/DC switch.

6. Use the Horizontal POSITION control (26) to position any point of interest on the central vertical graticule line. This line has additional calibration marks equal to 0.2 major division each. The voltage relative to ground at any point selected is equal to the number of divisions from that point to the ground-reference line multiplied by the VOLTS/DIV setting. In the example used for Figure 2-8, the voltage for a 0.5V/div scale is 2.5V (5.0 div \times .5V).
 7. If $\times 5$ vertical magnification is used, divide the Step 6 voltage by 5. However, if $10\times$ attenuator probes are used, multiply the voltage by 10.
-

2-3-2 Time Interval Measurements

The second major measurement function of the triggered-sweep oscilloscope is the measurement of time interval. This is possible because the calibrated timebase results in each division of the CRT screen representing a known time interval.

Basic Technique. The basic technique for measuring time interval is described in the following steps. This same technique applies to the more specific procedures and variations that follow.

1. Set up scope as described in 2-3-2 Single-trace Operation.
 2. Set the A TIME/DIV switch (22) so the interval you wish to measure is totally on screen and as big as possible. Make certain the A VARIABLE control (25) is click-stopped fully clockwise. If not, any time interval measurements made under this condition will be inaccurate.
 3. Use the Vertical POSITION control (17) or (18) to position the trace so the central horizontal graticule line passes through the points on the waveform between which you want to make the measurement.
 4. Use the Horizontal POSITION control (26) to set the left-most measurement point on a nearly vertical graticule line.
 5. Count the number of horizontal graticule divisions between the Step 4 graticule line and the second measurement point. Measure to a tenth of a major division. Note that each minor division on the central horizontal graticule line is 0.2 major division.
 6. To determine the time interval between the two measurement points, multiply the number of horizontal divisions counted in Step 5 by the setting of the TIME/DIV switch. If the TIME VARIABLE knob (25) is pulled ($\times 10$ magnification), be certain to divide the TIME/DIV switch setting by 10.
-

Period, Pulse Width, and Duty Cycle. The basic technique described in the preceding paragraph can be used to determine pulse parameters such as period, pulse width, duty cycle, etc.

The period of a pulse or any other waveform is the time it takes for one full cycle of the signal. In Figure 2-9, the distance between points (A) and (C) represent one cycle; the time interval of this distance is the period. The time scale for the CRT display of Figure 2-9 A is 10mS/div, so the period is 70 milliseconds in this example.

Pulse width is the distance between points (A) and (B). In our example it is conveniently 1.5 divisions, so the pulse width is 15 milliseconds. However, 1.5 divisions is a rather small distance for accurate measurements, so it is advisable to use a faster sweep speed for this particular measurement. Increasing the sweep speed to 2mS/div as in Figure 2-9 B gives a large display, allowing more accurate measurement. An alternative technique useful for pulses less than a division wide is to pull the A VARIABLE knob (25) for $\times 10$ magnification, and reposition the pulse on screen with the Horizontal POSITION control (26). Pulse width is also called on time in some application. The distance between points (B) and (C) is then called off time. This can be measured in the same manner as pulse width.

When pulse width and period are known, duty cycle can be calculated. Duty cycle is the percentage of the period (or total of on and off times) represented by the pulse width (on time)

$$\text{Duty cycle (\%)} = \frac{\text{PW (100)}}{\text{Period}} = \frac{\text{A} \rightarrow \text{B (100)}}{\text{A} \rightarrow \text{C}}$$

$$\text{Duty cycle of example} = \frac{15\text{mS} \times 100}{70\text{mS}} = 21.4\%$$

2-3-3. Frequency Measurement

When a precise determination of frequency is needed, a frequency counter is obviously the first choice. A counter can be connected to the CH-1 OUTPUT connector (20) for convenience when both scope and counter are used. However, an oscilloscope alone can be used to measure frequency when a counter is not available, or modulation and/or noise makes a counter unusable.

Frequency is the reciprocal of period. Simply measure the period "t" of the unknown signal as instructed in 2-4-2 Time Interval Measurements, and calculate the frequency "f" using the formula $f = 1/t$. If a calculator is available, simply enter the period and press the 1/x key. Period in seconds (S) yields frequency in Hertz (Hz); period in millisecond (mS) yields frequency in kilohertz (kHz); period in microseconds (uS) yields frequency in megahertz (MHz). The accuracy of this technique is limited by the timebase calibration accuracy (see Table of Specifications.)

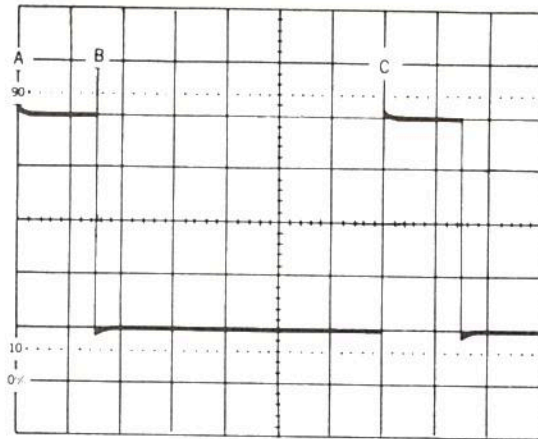

a. 10 MS DIVISION

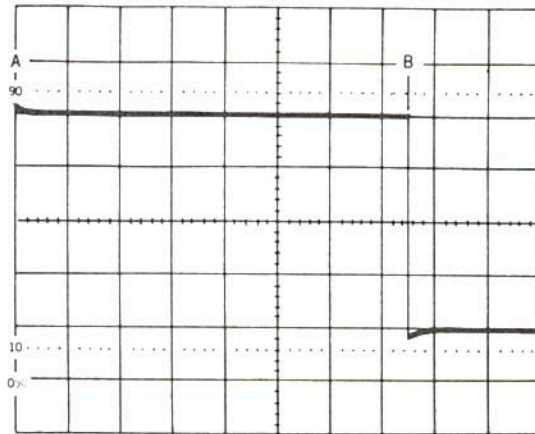

b. 2MS DIVISION

FIGURE 2-9. TIME INTERVAL MEASUREMENT

2-3-4. Phase Difference Measurements

Phase difference or phase angle between two signals can be measured using the dual-trace feature of the oscilloscope, or by operating the oscilloscope in the X-Y mode.

Dual-trace Method. This method works with any type of waveform. In fact, it will often work even if different waveforms are being compared. This method is effective in measuring large or small differences in phase, at any frequency up to 40 MHz.

To measure phase difference by the dual-trace method, proceed as follows :

1. Set up the scope as described in 2-3-3 Dual-trace Operation, connecting one signal to the CH1 IN connector (9) and the other to the CH2 IN connector (10).

NOTE : At high frequencies use identical and correctly-compensated probes, or equal lengths of the same type of coaxial cable to ensure equal delay times.

2. Position the Trigger SOURCE switch (28) to the channel with the cleanest and most stable trace. Temporarily move the other channel's trace off the screen by means of its Vertical POSITION control.
 3. Center the stable (trigger source) trace with its Vertical POSITION control, and adjust its amplitude to exactly 6 vertical divisions by means of its VOLTS/DIV switch and VARIABLE control.
 4. Use the Trigger LEVEL control (30) to ensure that the trace crosses the central horizontal graticule line at or near the beginning of the sweep. See Figure 2-10.
 5. Use the A TIME/DIV switch (22), A VARIABLE control (25), and the Horizontal POSITION control (26) to display one cycle of trace over 7.2 divisions. When this is done, each major horizontal division represents 50°, and each minor division represents 10°.
 6. Move the off-screen trace back on the CRT with its Vertical POSITION control, precisely centering it vertically. Use the associated VOLTS/DIV switch and VARIABLE control to adjust its amplitude to exactly 6 vertical divisions.
 7. The horizontal distance between corresponding points on the waveform is the phase difference. For example, in the Figure 2-10 illustration the
-

phase difference is 6 minor divisions, or 60° .

8. If the phase difference is less than 50° (one major division), pull the A VARIABLE knob to activate the PULL $\times 10$ MAG switch, and use the Horizontal POSITION control (if needed) to position the measurement area back on screen. With $10\times$ magnification, each major division is 5° and each minor division is 1° .

Lissajous Pattern Method. This method is used primarily with sine waves. Measurements are possible at frequencies up to 500 KHz, the bandwidth of the horizontal amplifier. However, for maximum accuracy, measurements of small phase differences should be limited to below 50 KHz.

To measure phase difference by the Lissajous pattern method, proceed as follows :

1. Rotate the A TIME/DIV switch fully clockwise to its X-Y position.

CAUTION : Reduce the trace intensity
lest the undeflected spot damage the
CRT phosphor.

2. Make sure the CH2 POSITION/PULL $\times 10$ MAG knob (18) is pushed in. This will introduce a 180° phase error if pulled out.
 3. connect one signal to the CH1 or X IN connector (9), and the other signal to the CH2 or Y IN connector (10).
 4. Center the trace vertically with the CH2 Vertical POSITION control (18), and adjust the CH2 VOLTS/DIV switch (14) and VARIABLE control (16) for a trace height of exactly 6 divisions (the 100% and 0% graticule lines tangent to the trace).
 5. Adjust the CH1 VOLTS/DIV switch (13) for the largest-possible on-screen display.
 6. Precisely center the trace horizontally with the Horizontal POSITION control (26).
-

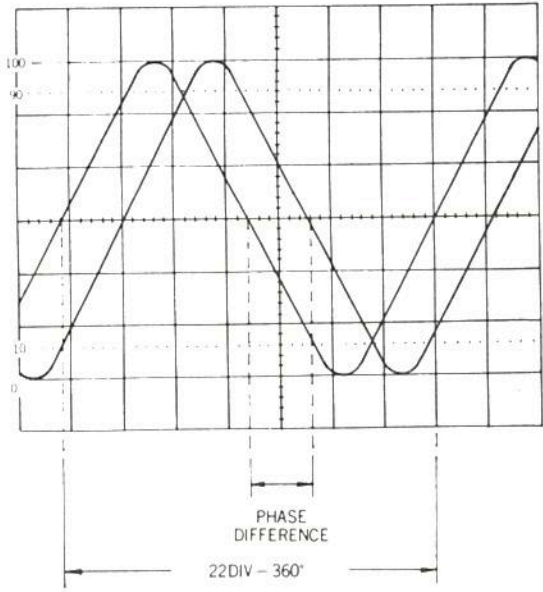
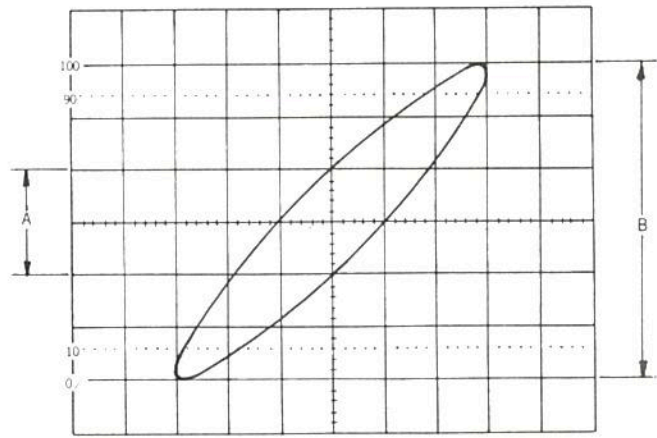
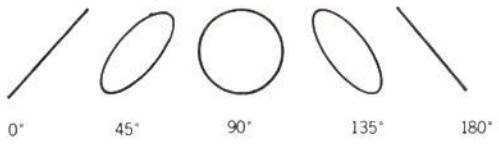

FIGURE 2 10. DUAL-TRACE METHOD OF PHASE MEASUREMENT



PHASE DIFFERENCE(angle θ) = $\sin^{-1} \frac{A}{B}$

a. PHASE ANGLE CALCULATION



b. LISSAJOUS-PATTERNS OF VARIOUS PHASE ANGLES

FIGURE 2-11. LISSAJOUS METHOD OF PHASE MEASUREMENT

7. Count the number of divisions subtended by the trace along the central vertical graticule line (dimension B). You can now shift the trace vertically with CH2 POSITION control to a major division line for easier counting.
8. The phase difference (angle θ) between the two signals is equal to the arc sine of dimension $A \div B$ (the Step 7 number divided by 6). For example, the Step 7 value of the Figure 2-11a pattern is 2.0. Dividing this by 6 yields .3334, whose arcsine is 19.5° .
9. The simple formula in Figure 2-11a works for angles less than 90° . For angles over 90° (leftward tilt), add 90° to the angle found in Step 7. Figure 2-11b shows the Lissajous patterns of various phase angles ; use this as a guide in determining whether or not to add the additional 90° .

NOTE : The sine-to-angle conversion
can be accomplished by using trig tables
or a trig calculator.

2-3-5. Risetime Measurement

Risetime is the time required for the leading edge of a pulse to rise from 10% to 90% of the total pulse amplitude.

Falltime is the time required for the trailing edge of a pulse to drop from 90% of total pulse amplitude to 10%. Risetime and falltime, which may be collectively called transition time, are measured in essentially the same manner.

To measure rise and fall time, proceed as follows :

1. Connect the pulse to be measured to the CH-1 IN connector (9), and set the AC GND DC switch (11) to AC.
 2. Adjust the A TIME DIV switch (22) to display about 2 cycles of the pulse. Make certain the A VARIABLE control (25) is rotated fully clockwise and pushed in.
 3. Center the pulse vertically with the channel 1 Vertical Position control(17).
 4. Adjust the channel 1 VOLTS/DIV switch (13) to make the positive pulse peak exceed the 100% graticule line, and the negative pulse peak exceed the 0% line, then rotate the VARIABLE control (15) counterclockwise until the positive and negative pulse peaks rest exactly on the 100% and 0% graticule lines. (See Figure 2-12).
 5. Use the Horizontal POSITION control (26) to shift the trace so the leading edge passes through the intersection of the 10% and central vertical graticule lines.
 6. If the risetime is slow compared to the period, no further control manipulations are necessary. If the risetime is fast(leading edge almost vertical), pull the A VARIABLE PULL $\times 10$ MAG control (25) and reposition the trace as in Step 5. (See Figure 2-12b.)
 7. Count the number of horizontal divisions between the central vertical line(10% point) and the intersection of the trace with the 90% line.
 8. Multiply the number of divisions counted in Step 7 by the setting of the TIME/DIV switch to find the measured risetime. If $10\times$ magnification was used, divide the TIME DIV setting by 10. For example, if the A timebase setting in Figure 2-12 was 1 S/div (1000nS), the risetime would be 360 nanoseconds ($1000 \text{ nS} \div 10 = 100 \text{ nS}$, $100 \text{ nS} \times 3.6 \text{ div} = 360\text{nS}$).
 9. To Measure falltime, simply shift the trace horizontally until a trailing edge passes through the 10% and central vertical graticule lines, and repeat Steps 7 and 8.
 10. The rise and fall times measured thus far include the 8.8nS transition times of the OS-9000SRS.
These errors are negligible if the measured rise and fall times are 35 nS or longer. For shorter transition times, correct the measured rise and fall times using one of the following formula :
-

$$t_c = \sqrt{t_m^2 - 77}$$

(t_c = corrected transition time)
(t_m = measured transition time)

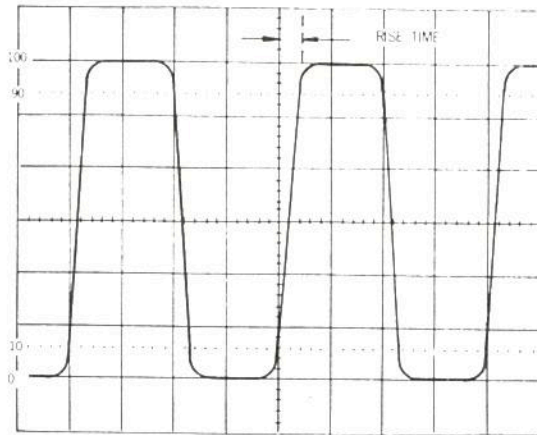

a. BASIC DISPLAY SETUP

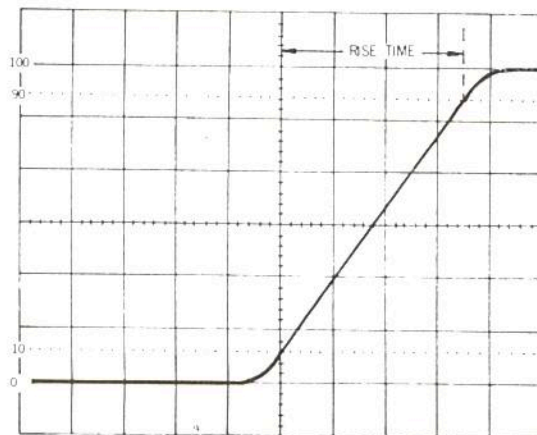

b. WITH HORIZONTAL MAGNIFICATION

FIGURE 2-12. RISE TIME MEASUREMENT

3. USER MAINTENANCE ROUTINES

Maintenance routines performable by the OS-9000SRS operator are listed in this section. More advanced routines (i.e., procedures involving repairs or adjustments within the instrument) should be referred to Gold Star service personnel.

3-1. CLEANING

If the outside of the case becomes dirty or stained, carefully wipe the soiled surface with a rag moistened with detergent, then wipe the cleaned surface with a dry cloth. In case of severe stain, try a rag moistened with alcohol. Do not use powerful hydrocarbons such as benzene or paint thinner.

Dust and /or smudges can be removed from the CRT screen. First remove the front case and filter (see Figure 3-1). Clean the filter (and the CRT face, if necessary) by wiping carefully with a soft cloth or commercial wiping tissue moistened with a mild cleaning agent. Take care not to scratch them. Do not use abrasive cleanser or strong solvents. Let the cleaned parts air dry thoroughly before reinstalling the filter and front case. If installed wet, water rings may form and blur the waveforms. Be particularly careful not to get fingerprints on the filter or CRT face.

3-2. CALIBRATION INTERVAL

To maintain the accuracy specifications of the OS-9000SRS, calibration checks and procedures should be performed after every 1000 hours of service. However, if the instrument is used infrequently, the calibration checks should be performed every six months.

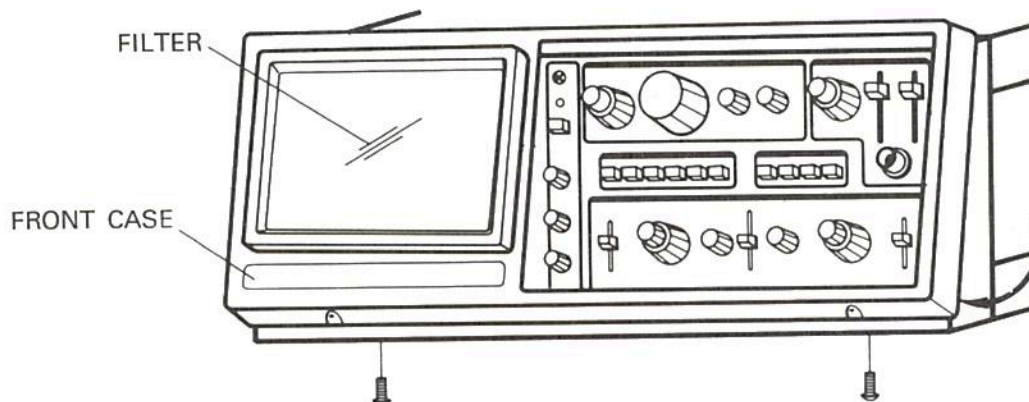
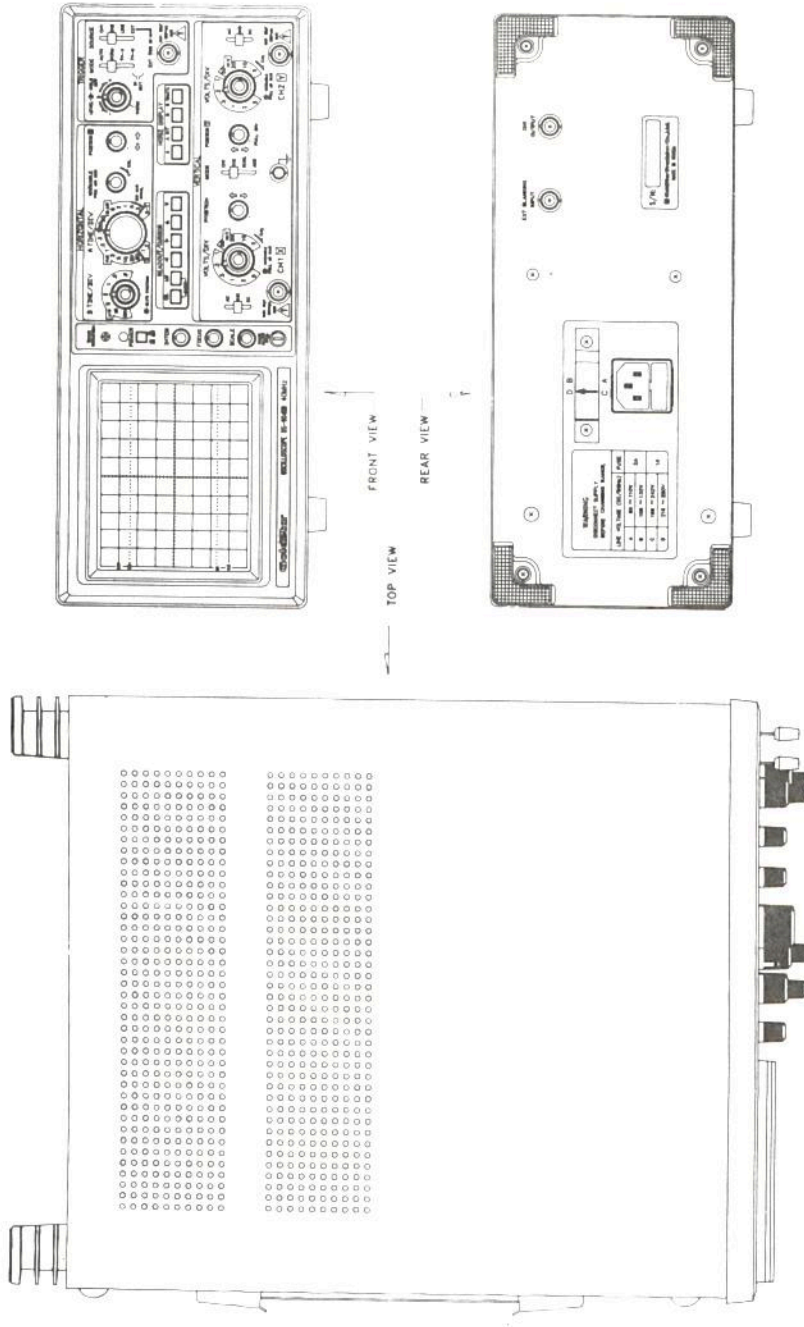

FIGURE 3-1. FRONT CASE AND FILTER

4. DIAGRAMS

4-1. EXTERNAL VIEWS



4-2. SCHEMATIC DIAGRAMS

4-2-1. Block Diagram

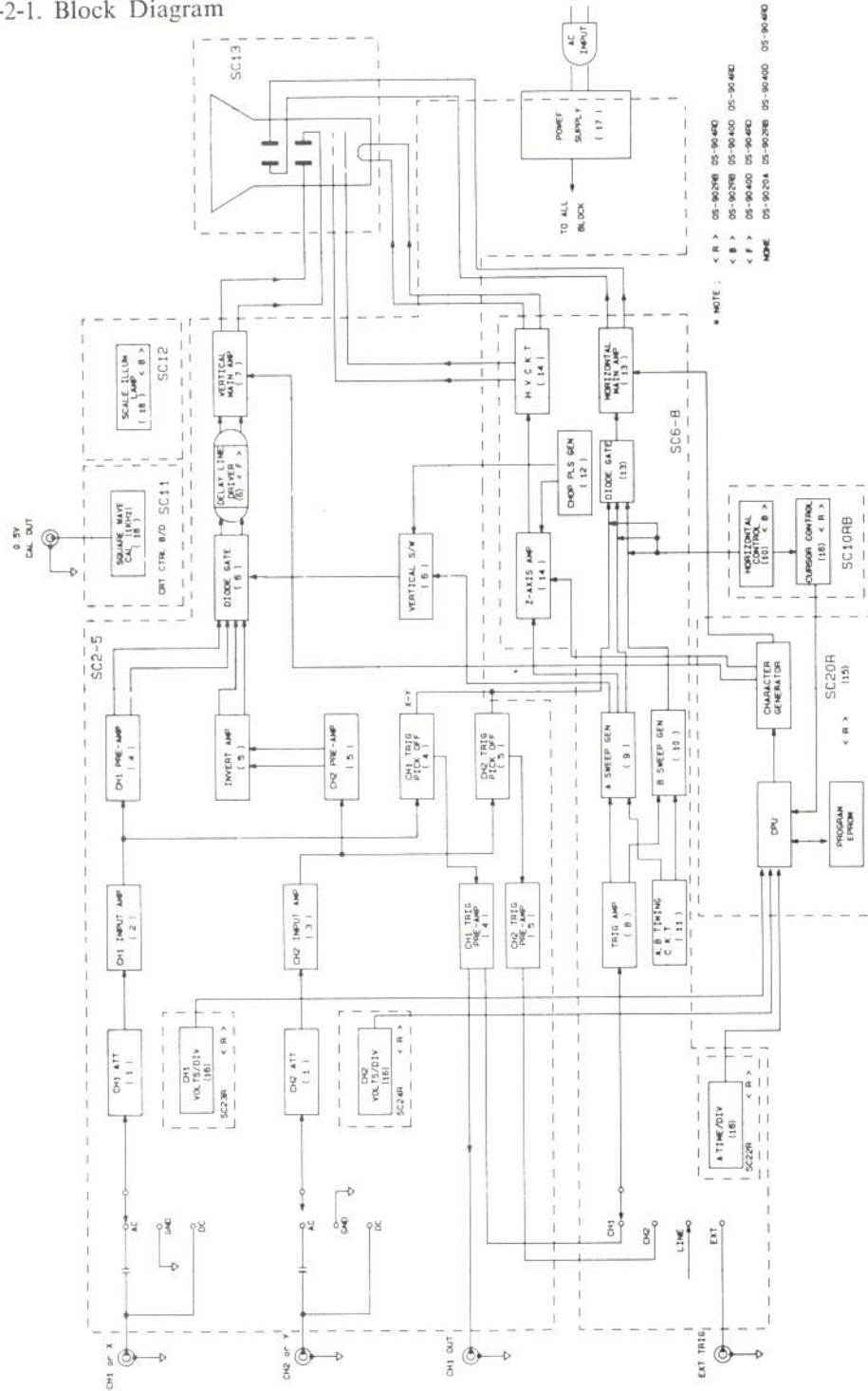

4-2.2. Wiring Diagram

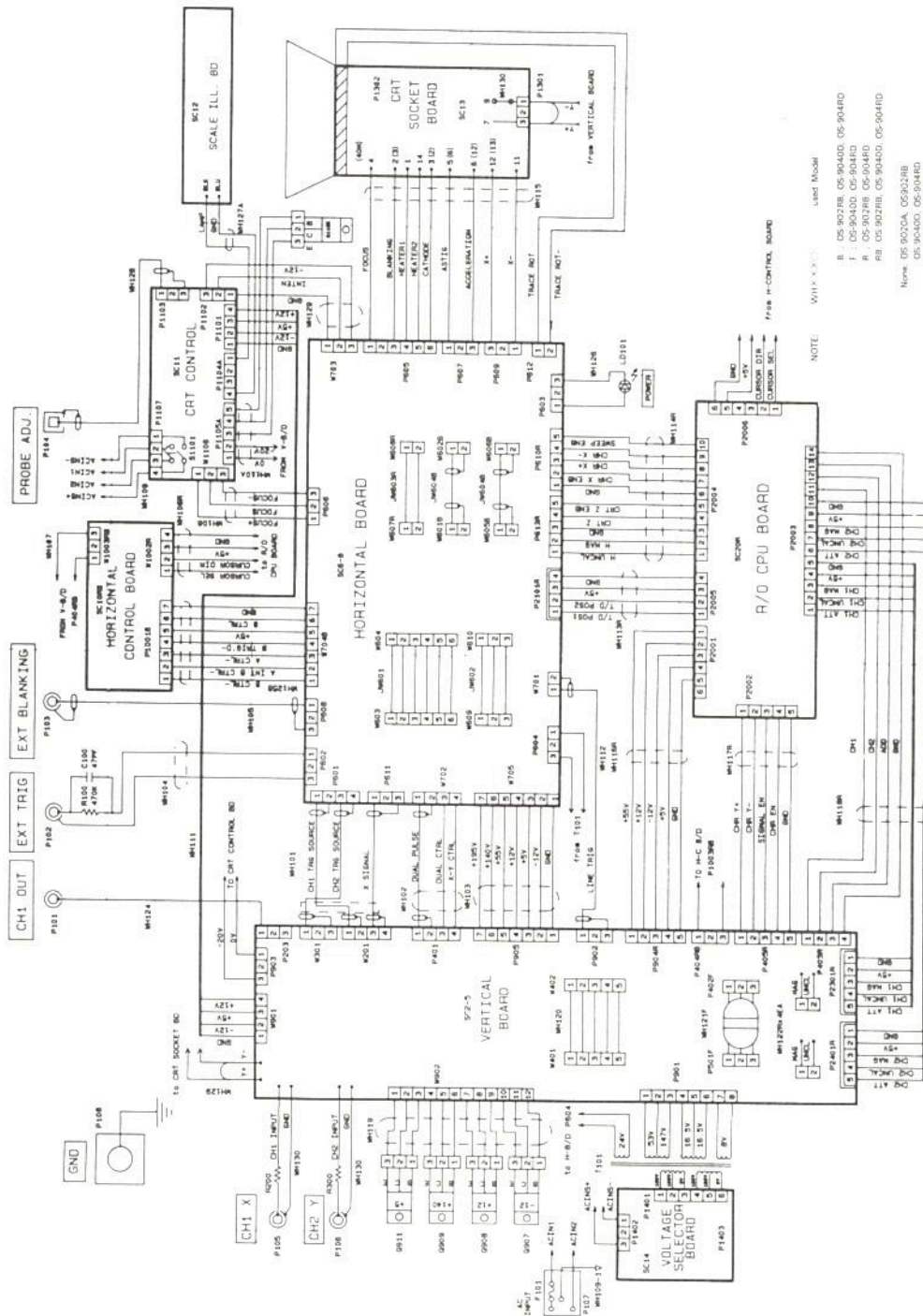

4-2-3. Circuit Diagrams

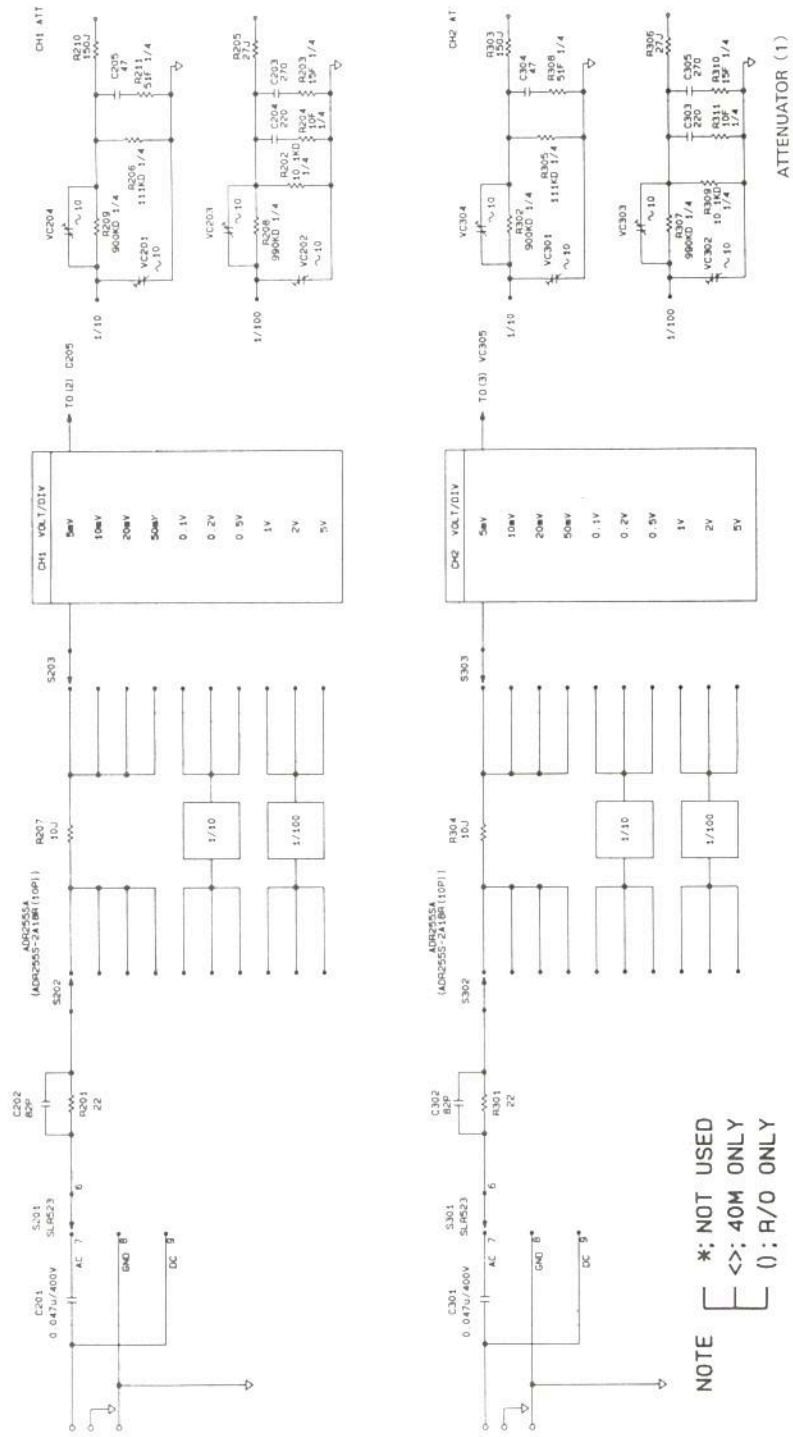

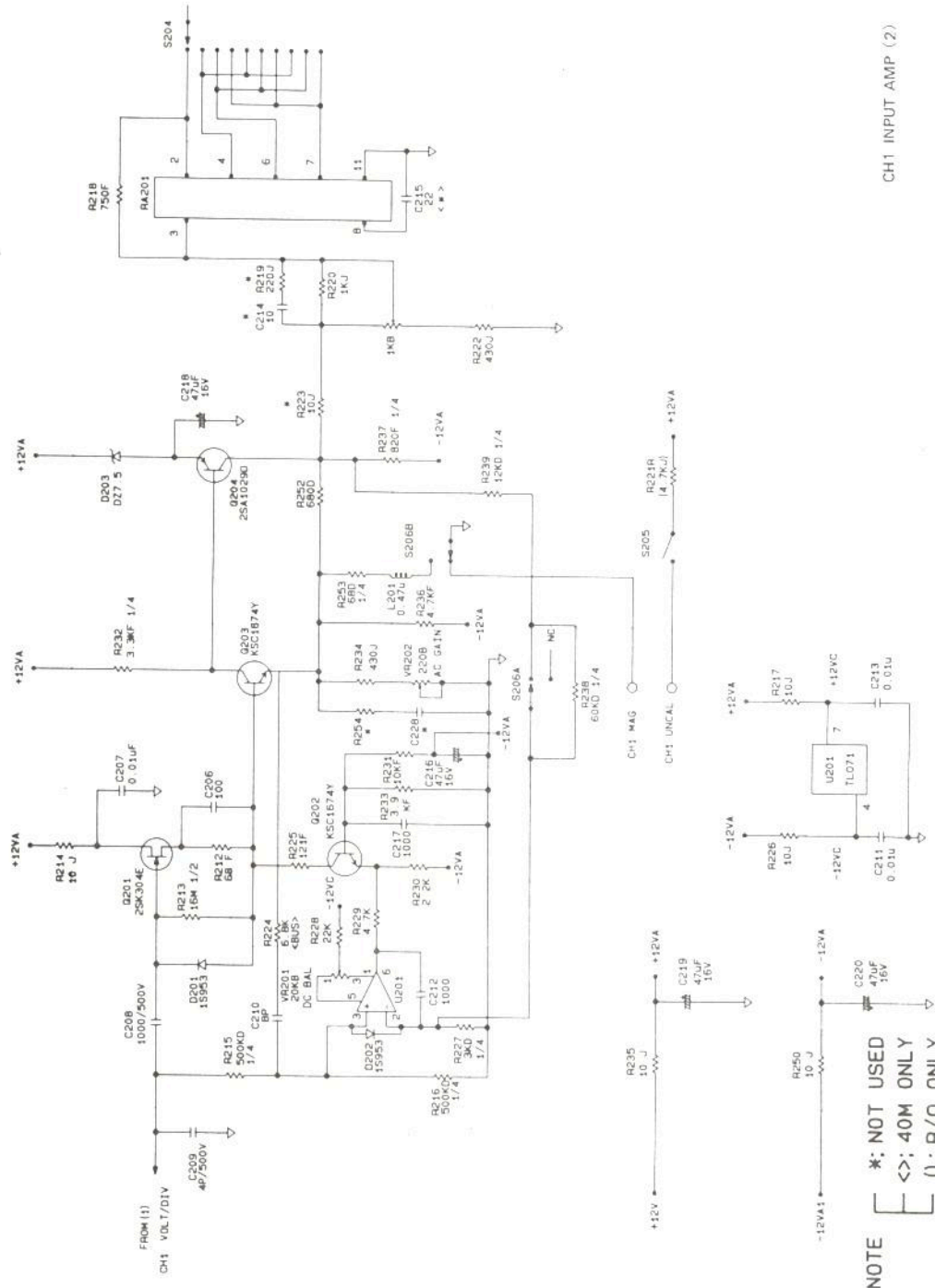

CH1 INPUT AMP (2)

NOTE
 * : NOT USED
 $\langle \rangle$: 40M ONLY
 () : R/O ONLY

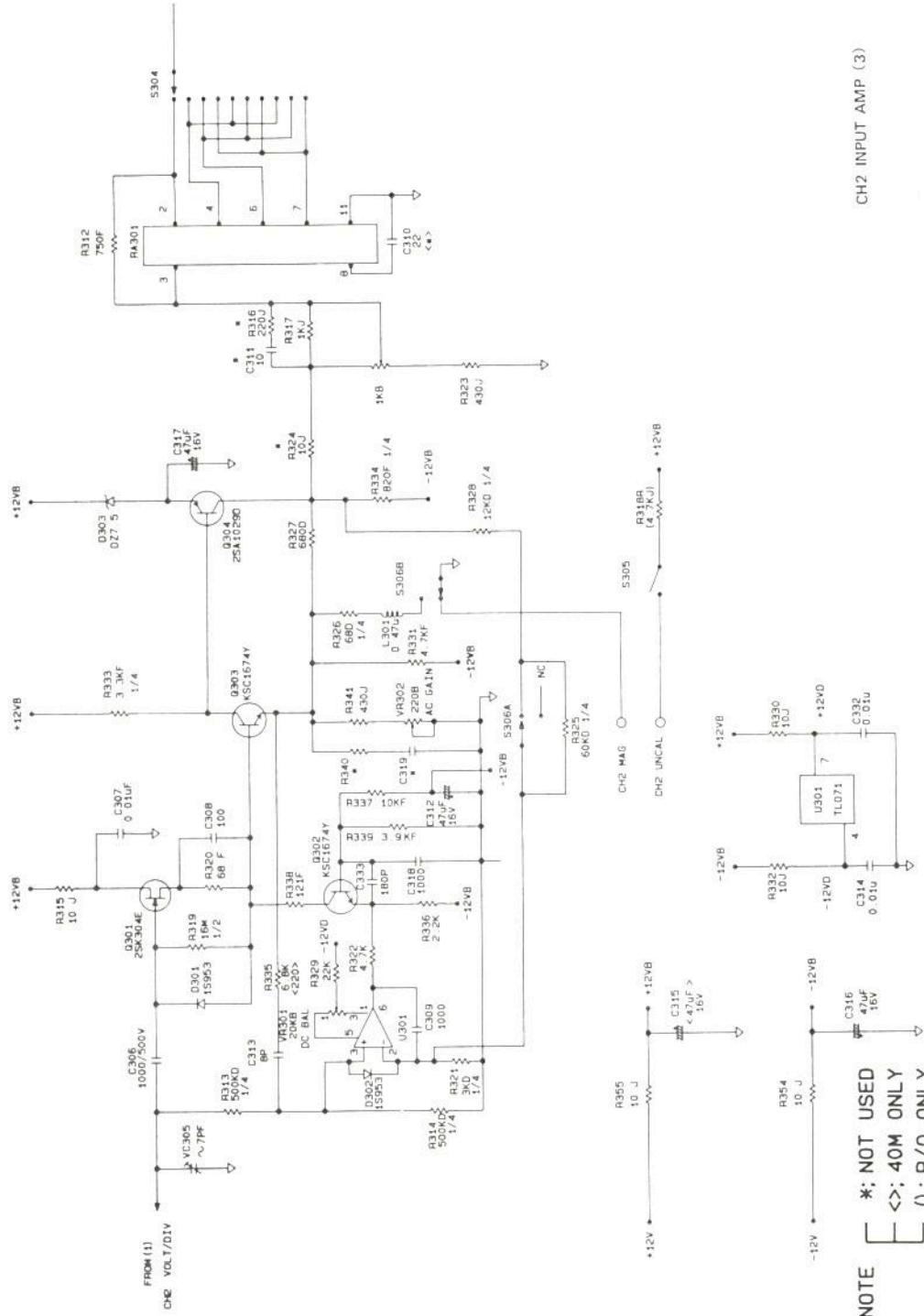

CH2 INPUT AMP (3)

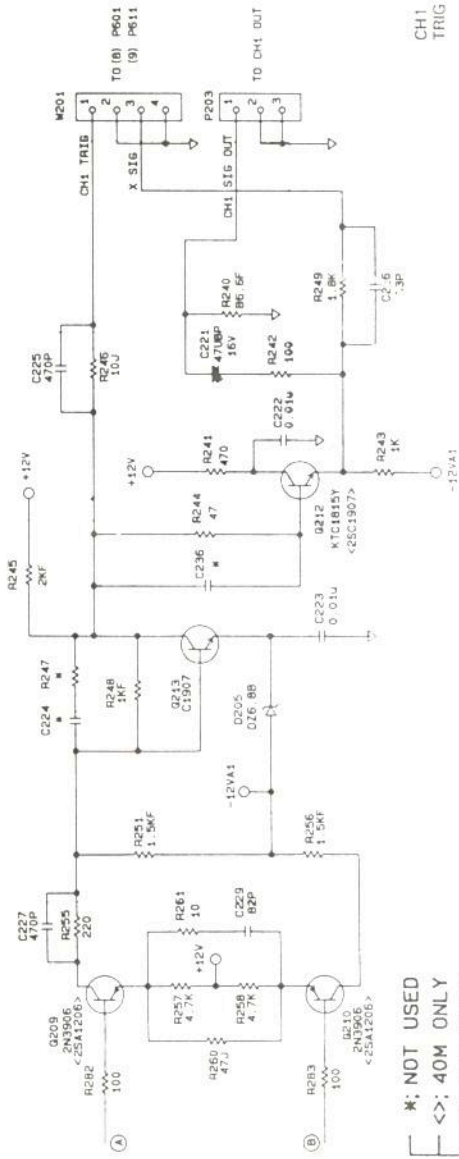
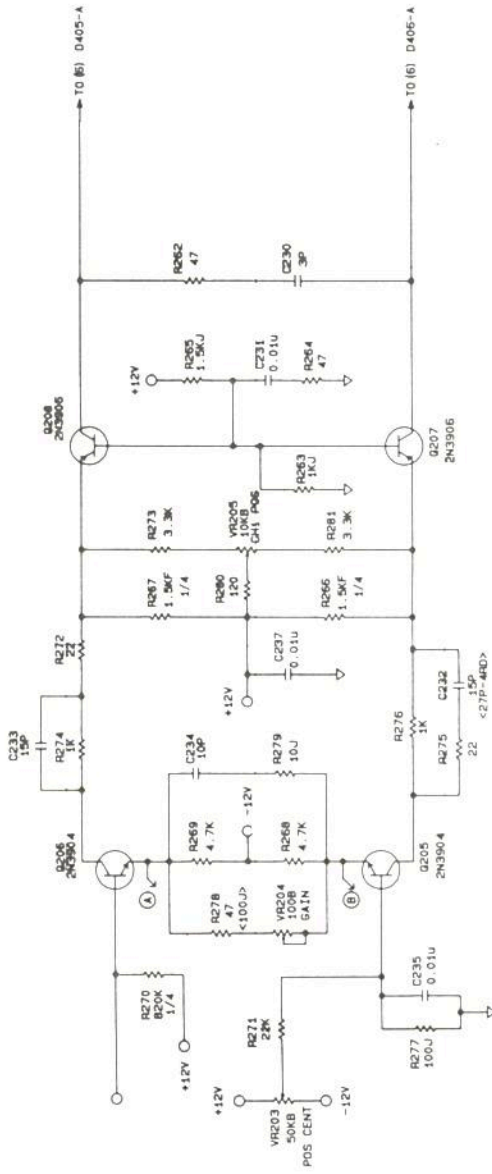

NOTE * : NOT USED
 E <> : 40M ONLY
 E 0 : R/O ONLY

CH1 PRE AMP &
 TRIG PICK OFF (4)

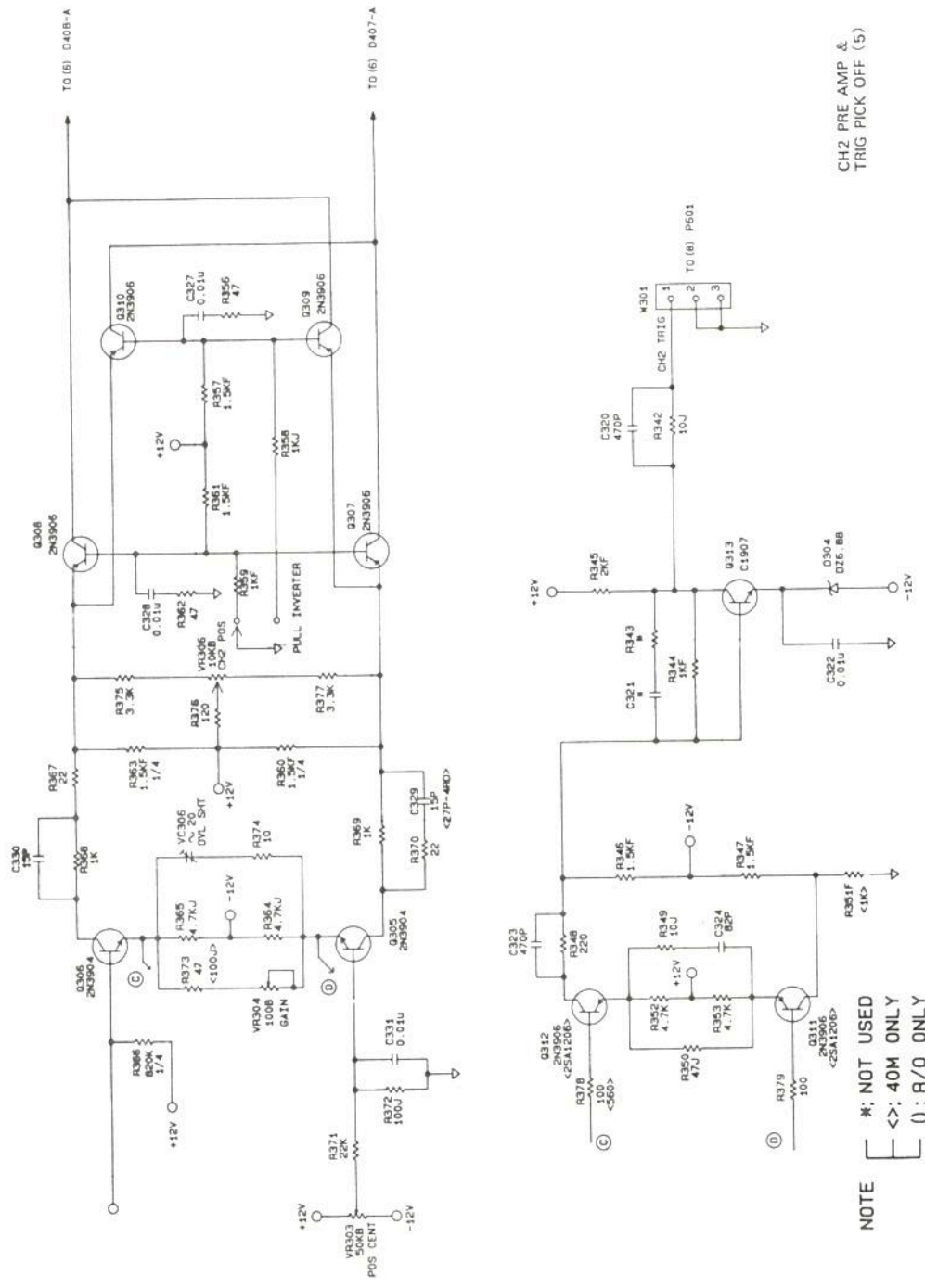

CH2 PRE AMP & TRIG PICK OFF (5)

NOTE #: NOT USED
E <->: 40M ONLY
() : R/O ONLY

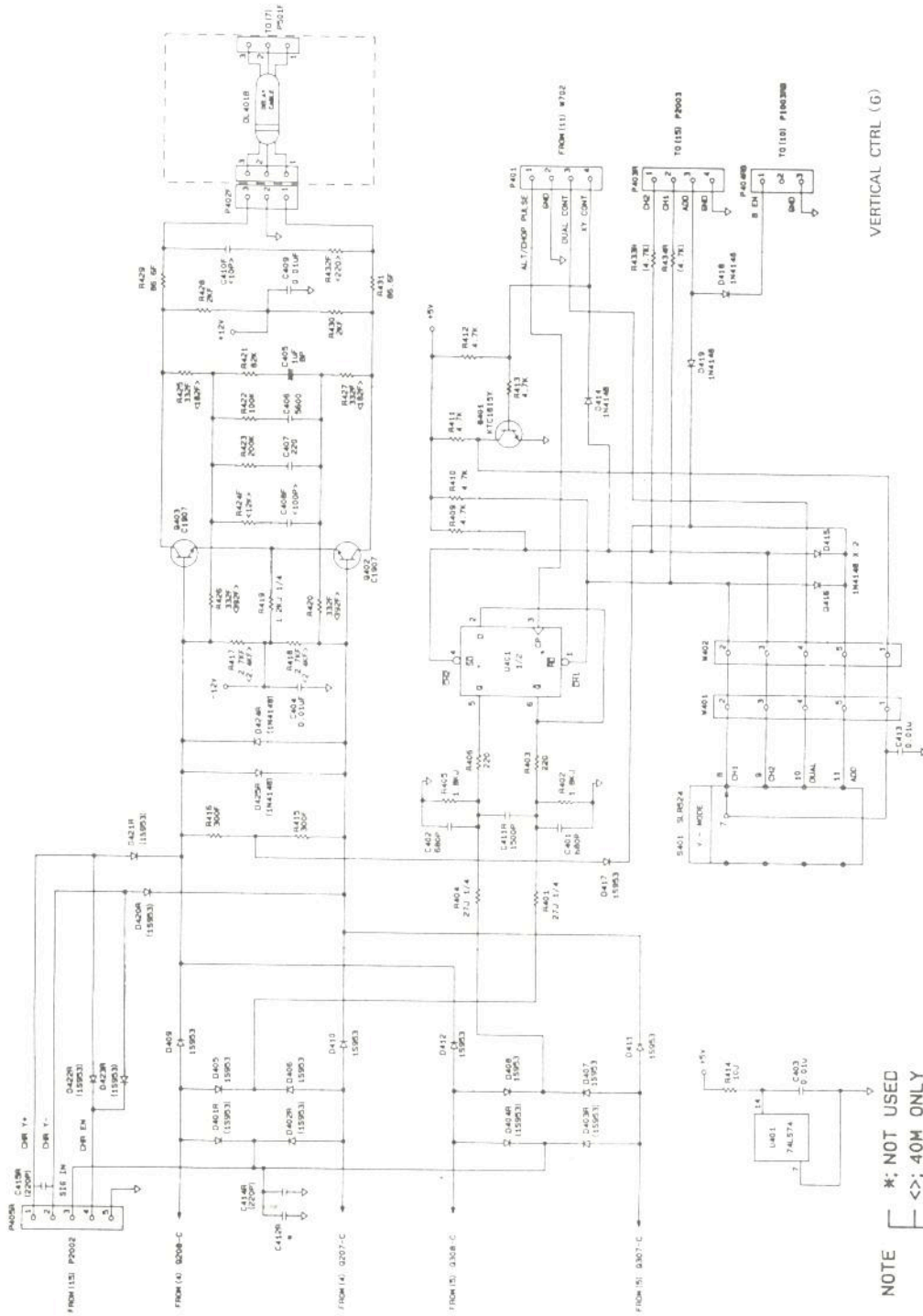

VERTICAL CTRL (G)

NOTE *; NOT USED
E <>; 40M ONLY
E 0; R/O ONLY

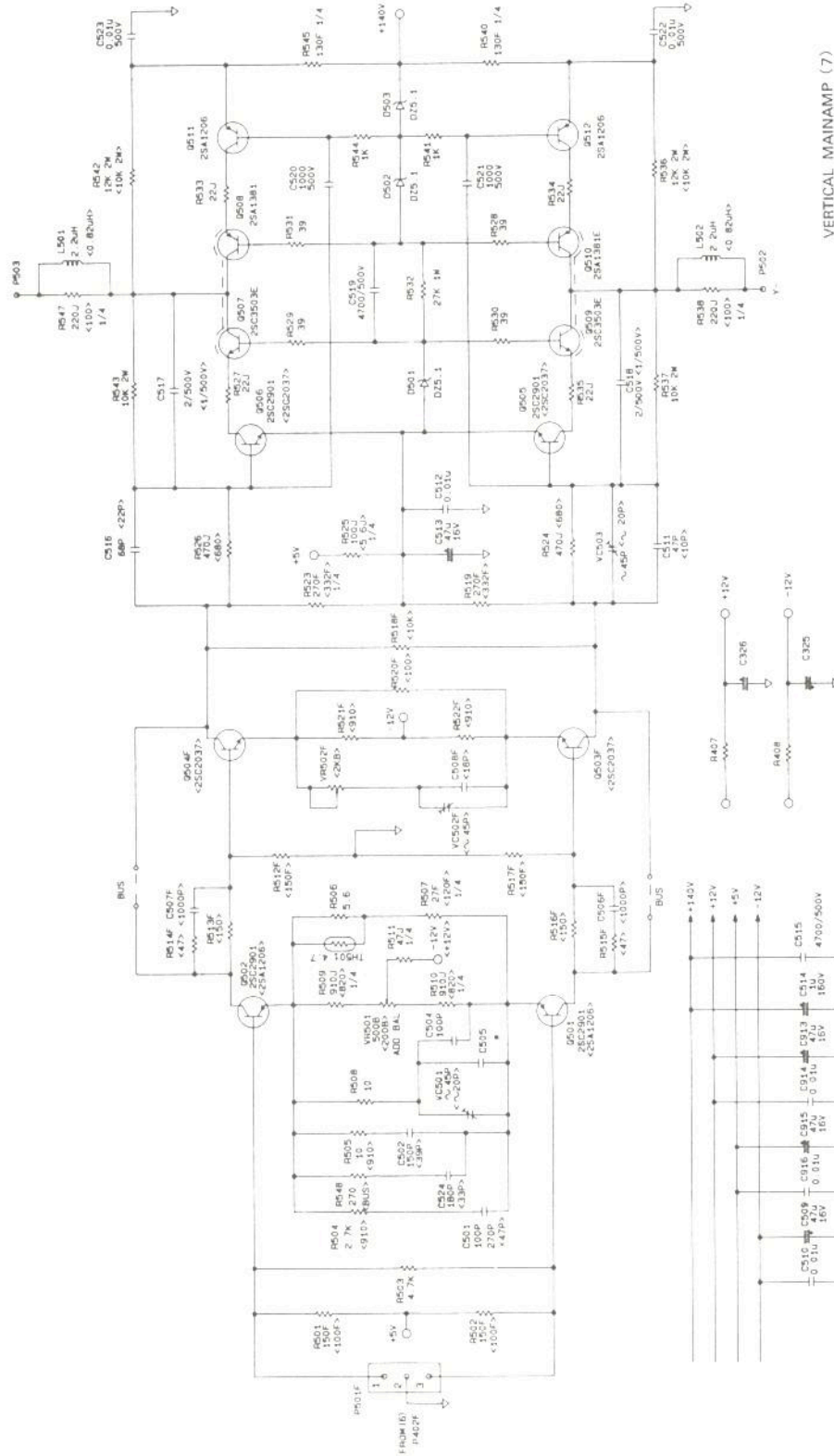

VERTICAL MAINAMP (7)

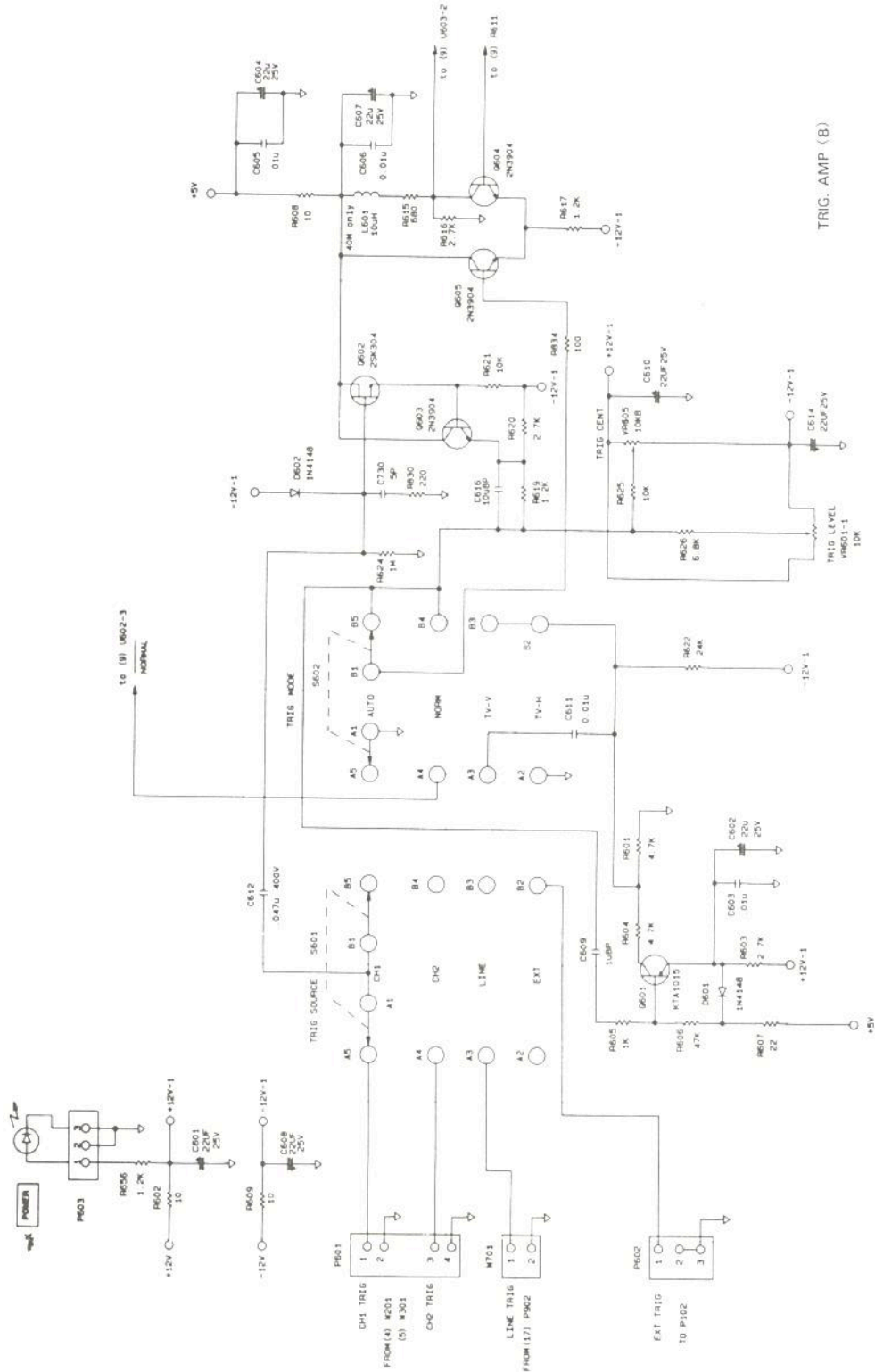

TRIG AMP (8)

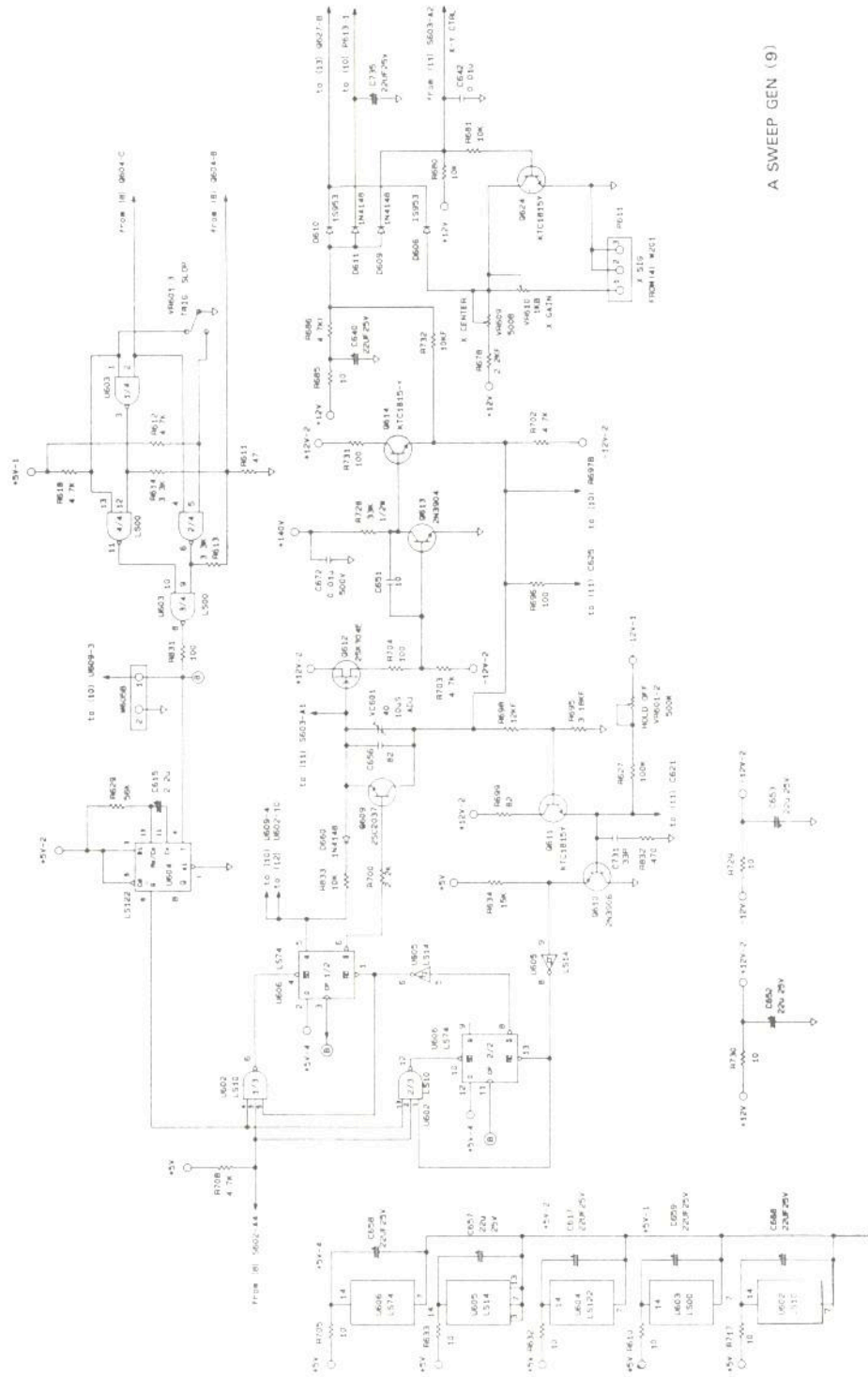

A SWEEP GEN (9)

HORIZONTAL CONTROL SC10

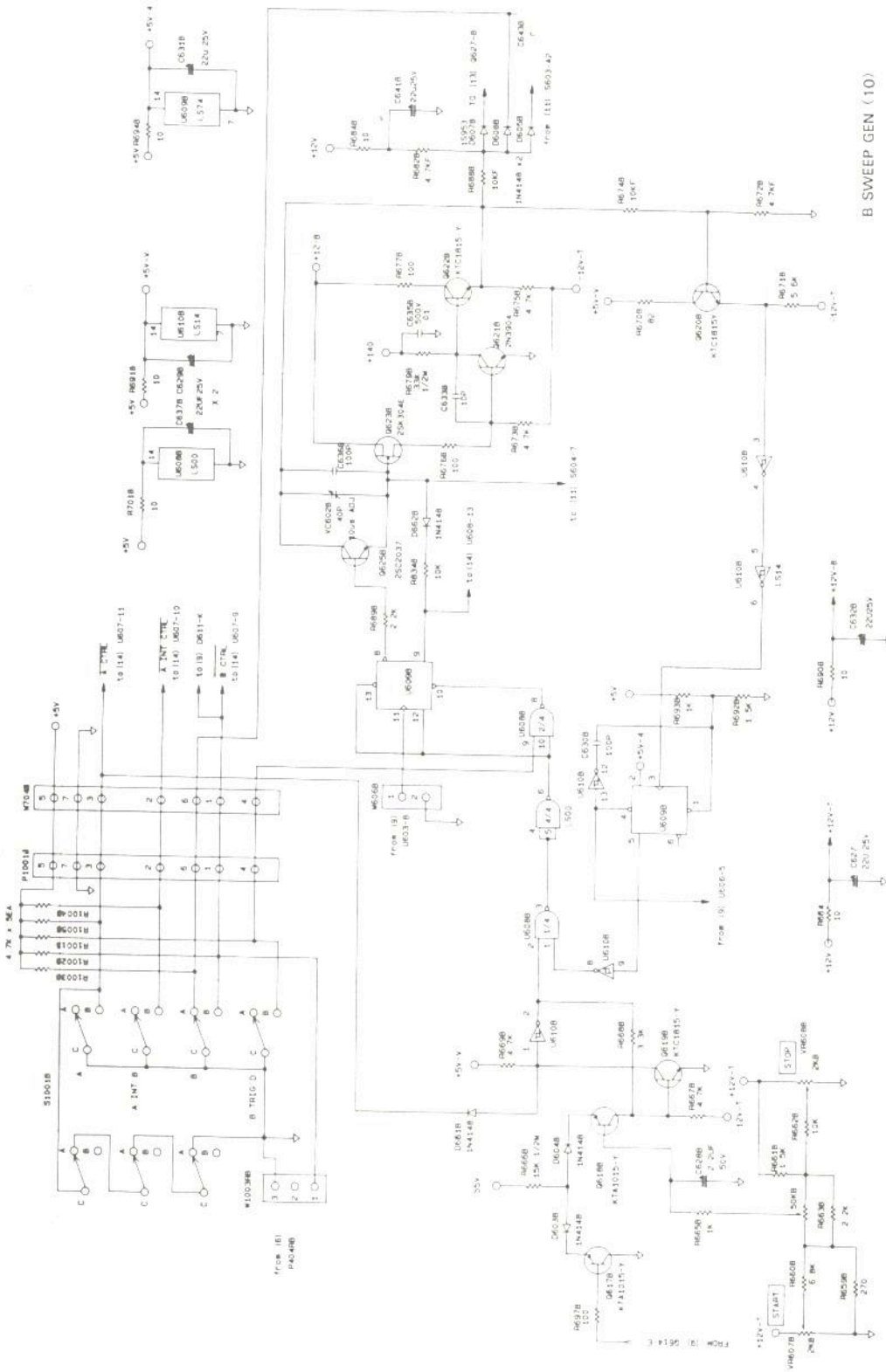

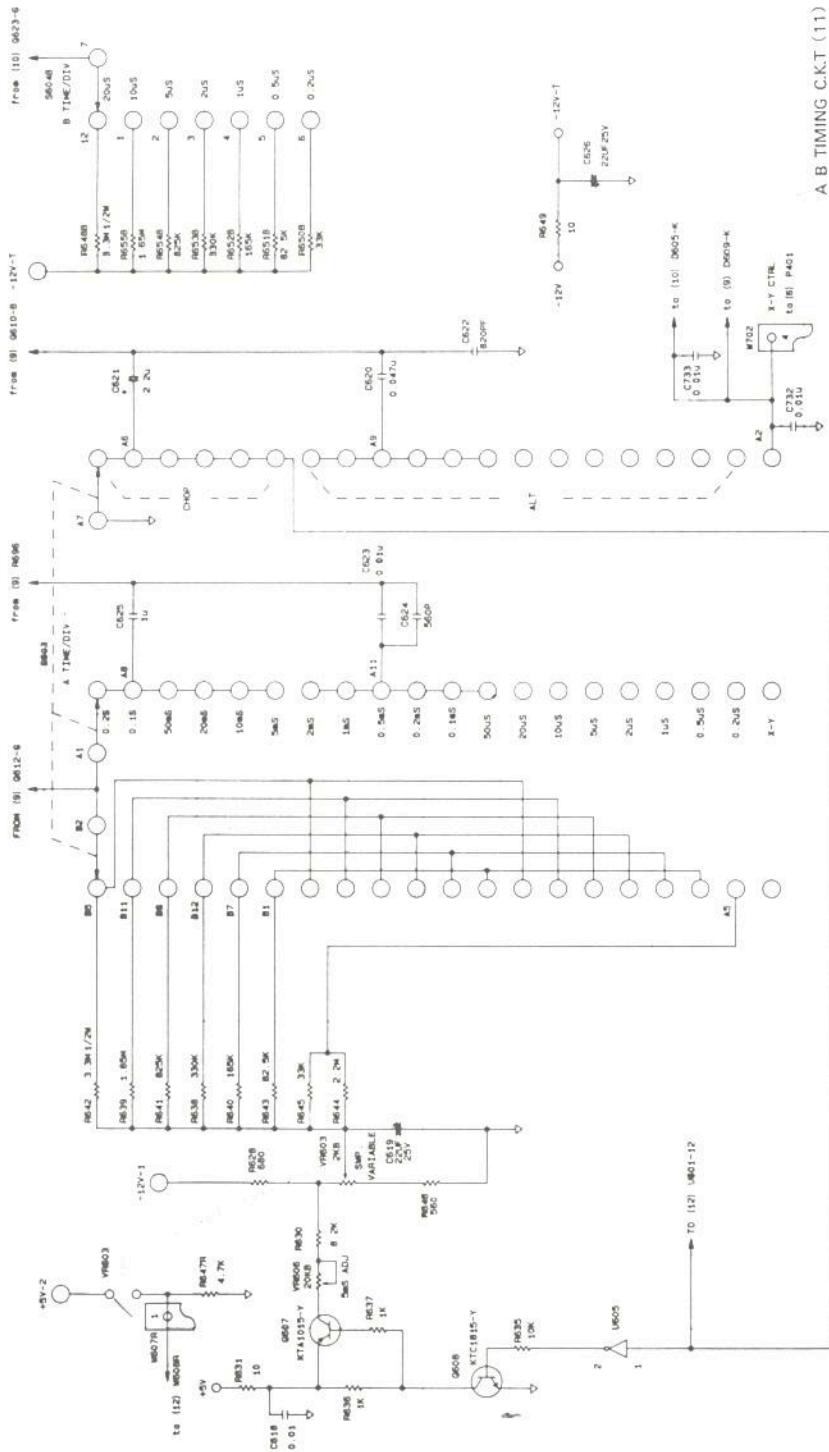

A B TIMING C.K.T (11)

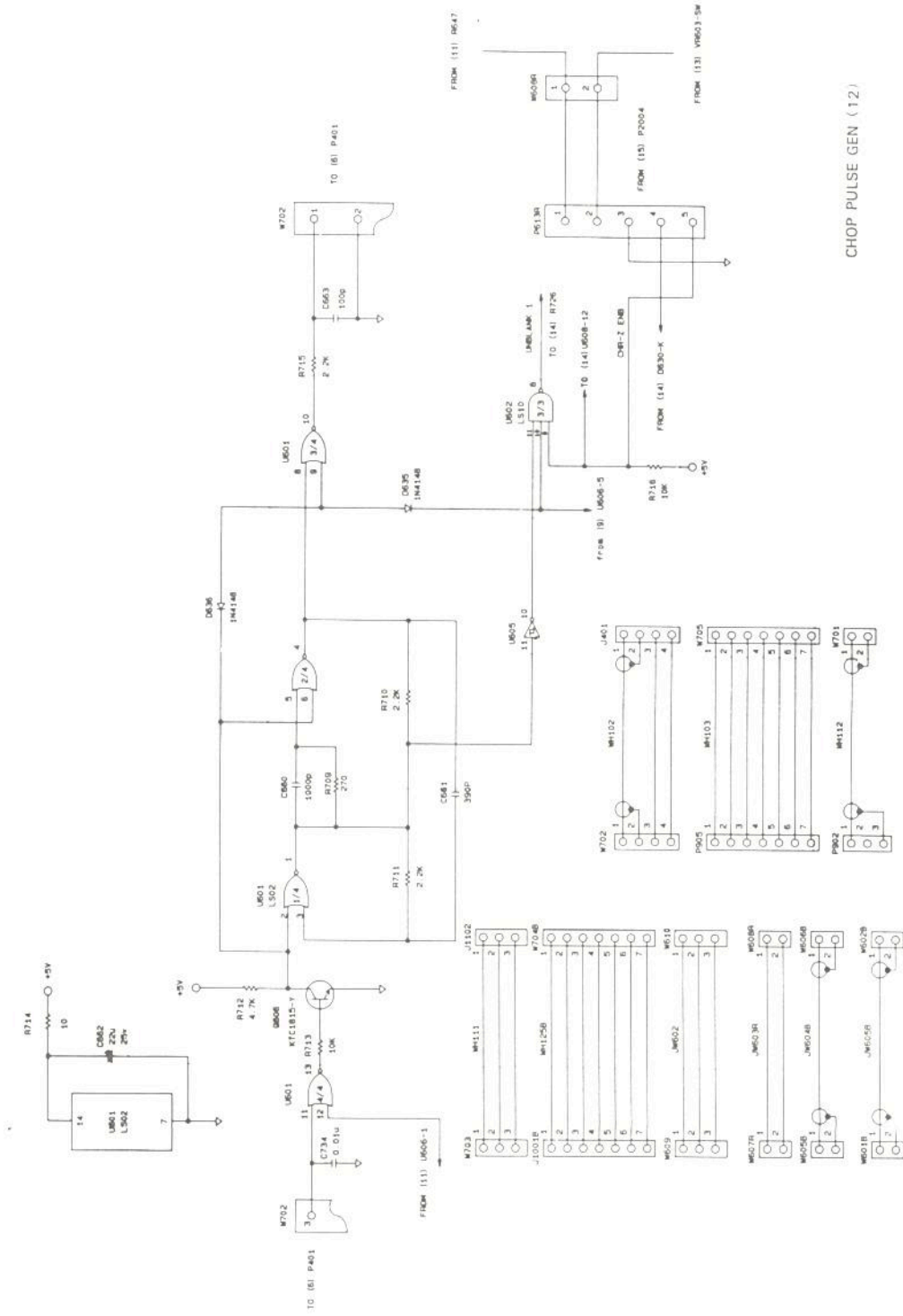

CHOP PULSE GEN (12)

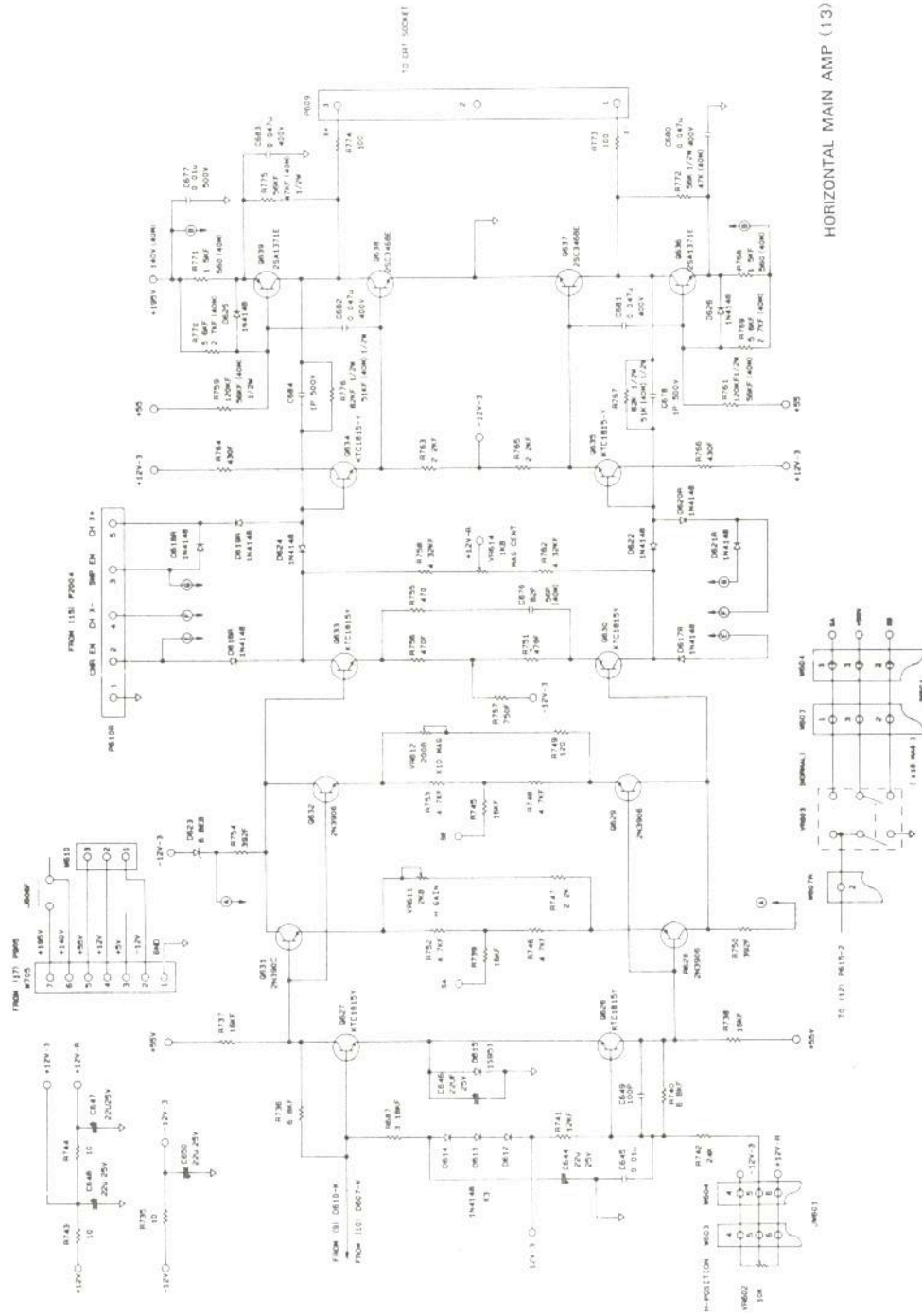

HORIZONTAL MAIN AMP (13)

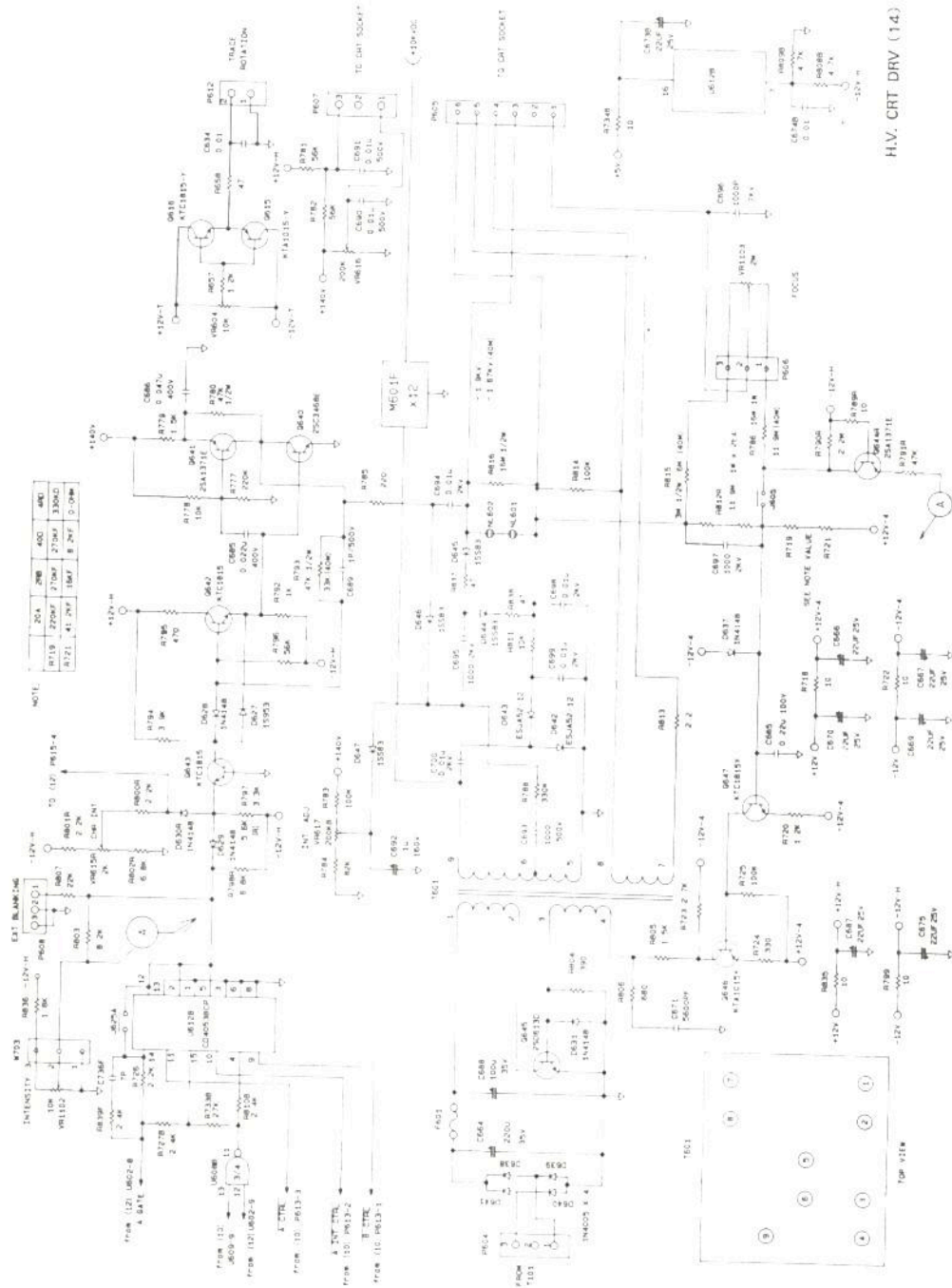

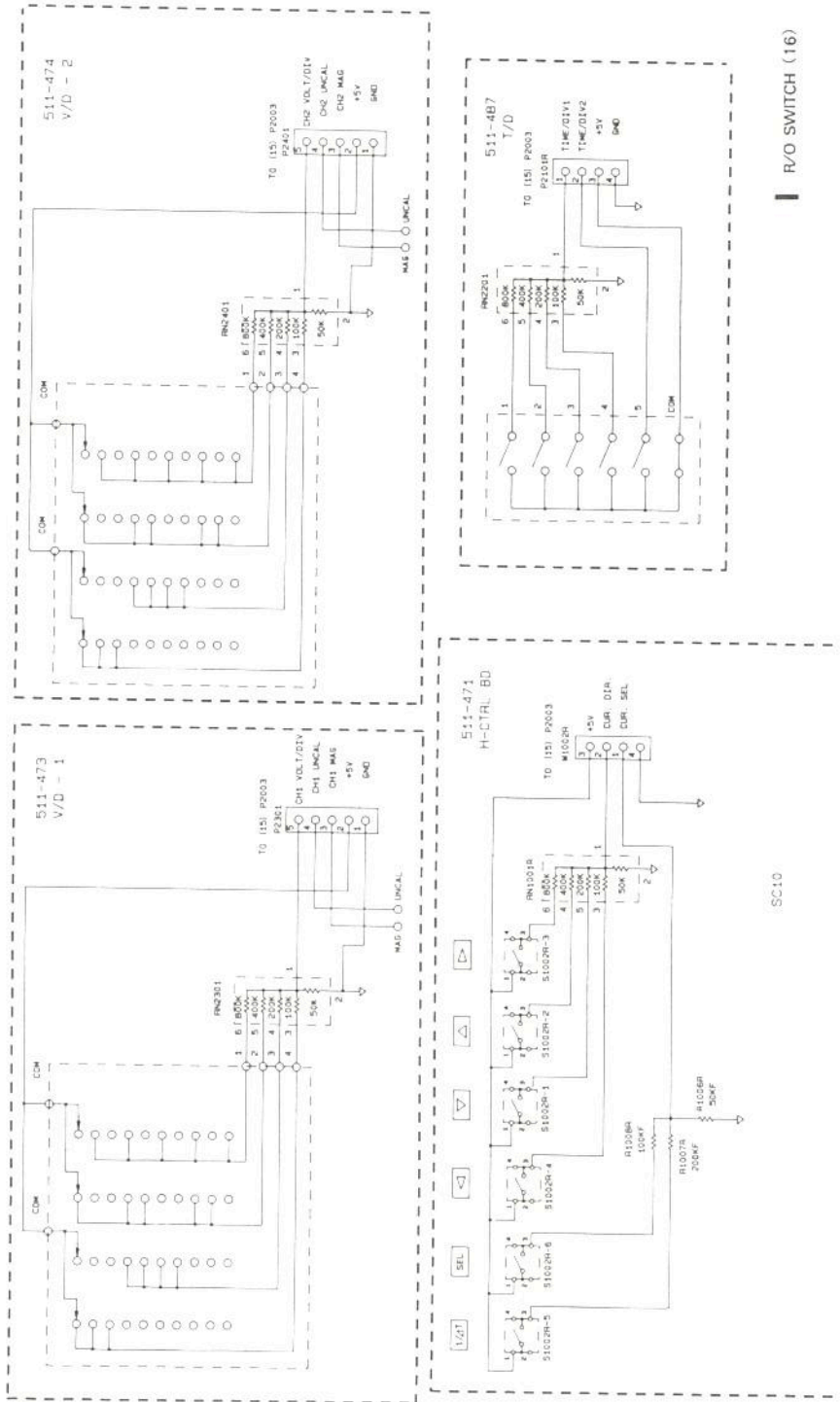

R/O SWITCH (16)

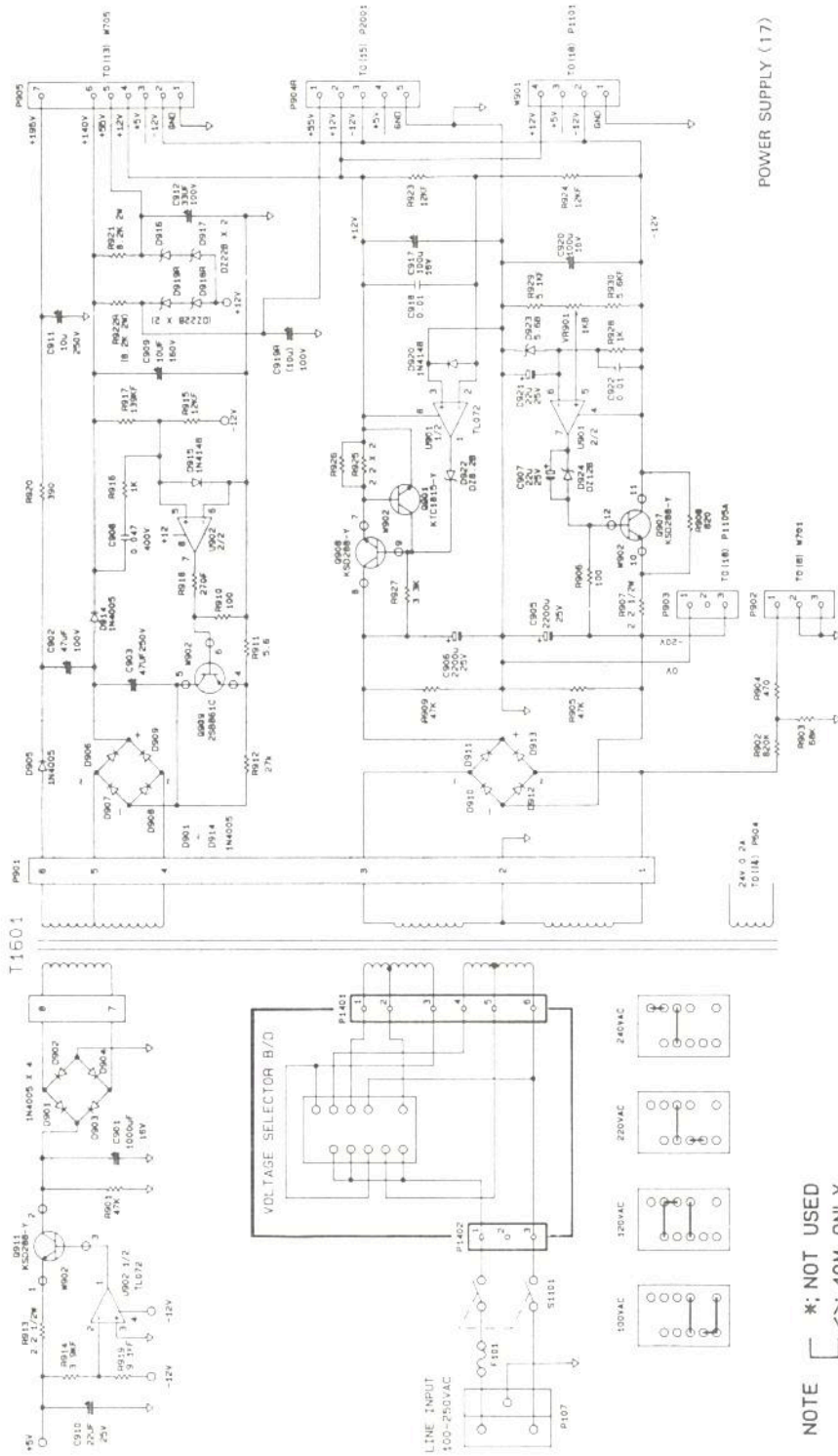

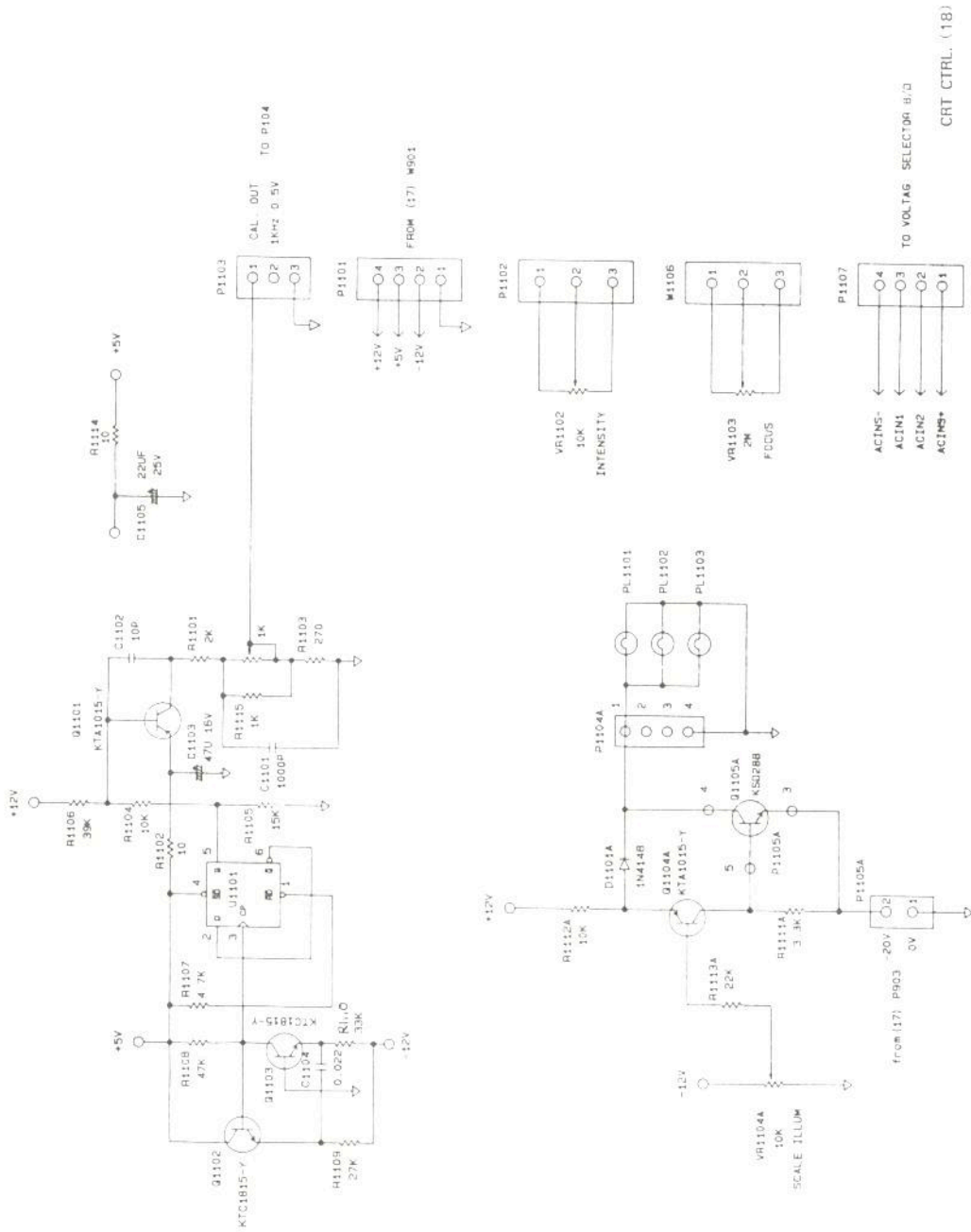

CRT CTRL. (18)

MEMO

MEMO

MEMO